

# TIPS – Chapter Eleven Modifications

## Table of Contents

MODERNIZATION MODIFICATION .....	3
ROBERTSON STOL MODIFICATION .....	3
HOERNER WING TIPS.....	5
HOERNER WING TIPS.....	6
DROOP WING TIPS .....	6
DEMER SUPER WING TIPS .....	6
INSTRUMENT PANEL MODIFICATION .....	7
TWIN MODERNIZATION .....	10
HOSKINS COMPUTER FUEL FLOW SYSTEM .....	11
TWIN PERFORMANCE .....	11
TACHOMETER Digital tachometers now STC'd for Comanche. ....	13
ONE PIECE WINDSHIELD INSTALLATION.....	14
ROBERTSON STOL MODIFICATION .....	14
AD 79-20-10, AILERON NOSE RIB CRACKS .....	14
TIP TANKS.....	15
AILERON AERO-TRIM SYSTEM.....	15
GAP SEALS .....	17
TWIN Q-TIP PROPS.....	18
MET-CO-AIRE WING TIPS.....	19
GAP SEALS .....	19
TURBO RAJAY KITS .....	20
BRAKES REPOSITIONED MODIFICATION .....	20
FUELTRON COMPUTER FUEL FLOW SYSTEM.....	20
FIREWALL FUEL AND OIL LINE MODIFICATION.....	22
BAGGAGE COMPARTMENT FUEL TANK .....	23
AILERON AERO-TRIM SYSTEM.....	23
CONTROL WHEEL MODIFICATION .....	24
NOSE WHEEL TIRE MODIFICATION .....	25
TWIN BAGGAGE DOOR MODIFICATION .....	25
SWITCH PANEL MODIFICATION .....	25
SPEEDBRAKES.....	27
FIREWALL FEED THROUGH.....	30
TANKS .....	31
THE ULTIMATE SPEED MOD.....	31
AD 79-20-10, ALTERNATE COMPLIANCE. ....	34
ALTERNATOR CONVERSION TIP .....	35
EXHAUST STACK RECOMMENATION: GULF COAST STACKS.....	36
ELECTRONIC IGNITION .....	36
SLICK LASAR MAGNETOS.....	41
FLYING THE LASAR SYSTEM.....	42
THE MYTHS OF SPEED MODS; DUAL EXHAUST SYSTEMS, AND COWLINGS.....	46
AN OLD APPROACH TO MAKE NEW REPLACEMENTS FOR PLASTIC INTERIOR PARTS .	49
ON SPEED MODS .....	52

I HEARD IT ON THE INTERNET ABOUT SPEED MODS..... 53

## **MODERNIZATION MODIFICATION**

I purchased the 1978 flagship in February 1974. It is a 1960 PA-24-250. Not being rich at the time, or since, and probably never ever, I felt that a Comanche fitted my budget, could with a modicum of tender loving care, a few ideas, some work, and an amount of money over a period of time give me a great, fast, comfortable, and beautiful airplane just as good as some, and better than most new planes produced today. I've systematically and in no particular order, updated the plane to what it is now. The paint job and design I did over three years ago with DuPont Imron Poly. The first work I did was the complete interior including the headliner. Early this year it was all replaced excepting the headliner with deep pile carpets and leather for the super luxurious feeling. 18 Pop has all new tinted glass, including a Miller one-piece windshield. Radios consists of King KMA20 Audio, KX170B's (2) with a K1201C and 214 omni, KR86 xponder, KN61 DME, and Collins 650 ADF. A blind encoder and Century I autopilot finishes off this Trade-A-Plane ad sounding section.

I have a tendency toward gadgets, to the amusement of my friends. I have an outside temperature gauge that displays Fahrenheit and centigrade by LED's. Even more prolific are my clocks - a clock with a sweep second hand, a Hobbshobbs meter for recording my flight time, a Davtron clock in GMT and several other timing features, the tachometer for engine time, and for redundancy don't forget I always have on my watch with all its functions.

18 Pop has built in oxygen for those high flights over the mountains, and though not related, the stabilator has the modification that removes the 203 mph speed restriction. Final modifications, done this year are PA-39 tip tanks. Kit number 4009 & installation instruction booklets TT-4 & 12070 supplied by Osborne Tank & Supply of Ora Grande, CA 92386. The PA-39 tanks are more pointed in front and look better but otherwise are the same tanks made for PA-24's. Paper work for the mod raises gross weight to 3,000 lbs. with no restriction that the increase must be fuel. Va is lowered to 129 from 144 however. Just recently I installed new rams horn control units used in the latter years on Comanches. These are more modern and allow built in mike switch and other switches such as trim and autopilot disconnect. Control unit is Piper Part Number 2665-2, coiled wire with seven wires is P/N 26934-0, mike switch is P/N 67463. So far these are still available but may not be for long. Two Comanche owners have ordered theirs since seeing mine.

I always keep my ship in tip-top airworthy condition. In almost five years I have flown 900 hours, mostly for fun and entertainment. I fly anywhere and everywhere. Mexico once, clear across the US twice, several times over half way across. Have flown to all Comanche Conventions since joining. Fly to most of the Southwest tribe Fly-Ins. Obtained my instrument and commercial tickets at the controls. Fly solid IFR behind my special instrument panel featured in the May Flyer that I almost forgot to mention. Incidentally, I have had over thirty requests for the drawings so far and will keep sending them as long as they are requested.

## **ROBERTSON STOL MODIFICATION**

The Robertson STOL Conversion makes the Comanche 400 an even more spectacular performer. The Robertson people claim that the conversion will not decrease the normal cruising speed, and this seems to be the case.

On December 19, 1974, I took my bird to New Orleans's Lake Front Airport and left it to have the STOL conversion accomplished. By leaving the airplane over the Christmas holiday, I obtained a discount. I didn't really need the airplane then, and was assured that everything would be done

within two weeks. There was difficulty regarding the delivery date. (See ED. NOTE at the end of this article.)

The STOL conversion consists of the following things: The cruising position of the ailerons is raised 2. According to Robertson, they found in tests that the ailerons were partially stalled in cruise. Raising them eliminates this condition, makes the airplane cruise with its nose down a bit more than usual, and according to them, increases the cruising speed slightly (3 to 5 mph). The ailerons are also "drooped." This means that they come down with the flaps halfway. Thus for takeoff one has half-flaps from wingtip to wingtip. When the flaps are lowered to the full down position. the ailerons come back up. A cuff is added to the leading edge of the wing so that the airfoil is no longer symmetrical but droops a bit on the lower side. Drooped wingtips are also installed, unless the airplane has tip tanks. Stall fences are added to the upper wing surfaces where the flaps and ailerons meet. These have the effect of reducing the lateral motion of the air across the wing. which of course does not contribute to lift. Finally, since the installation tends to produce a more nose-heavy condition, a spring is installed in the stabilator control system. When the flaps are lowered this spring is called upon to help the pilot with the back pressure.

One of the significant benefits gained from the conversion is an increase in the gross weight of 200 pounds - from 3600 to 3800. It is claimed that there is better aileron control with the conversion. This may be so. but to this pilot It wasn't noticeable, because the aileron control was always very good before the conversion. When the ailerons are drooped to act as flaps aileron control is heavy and a bit sluggish, but otherwise control is very good.

Performance figures, as published by Robertson, are given below. I have never made any precise checks, but at least roughly speaking they seem to be about right. The airplane lifts off quite nicely at 60 mph. whereas 80 mph was a good speed for liftoff before the conversion. I habitually flew the final approach at 95 mph before the conversion; whereas now I fly between 75 and 80 mph.

The STOL takeoff is spectacular. After a roll of something like 500 to 600 feet, the big bird responds to back pressure by pointing her 400 horse power nose up at about a 30 angle and keeping it there. Spectators have been heard to gasp and exclaim, "Look, he's going to stall out!" But it doesn't stall, it just keeps going up.

#### Robertson STOL Published Performance Data

	Takeoff over 50'	Takeoff Speed	Gnd Roll	App Speed	Landing Roll
Piper Handbook	1500'	80	980'	93	1820'
RB Normal	890'	60	550'	78	1245'
RB STOL	765'	52	415'	67	995'

In the last line of the preceding table, the figures are for Robertson's STOL technique. This technique is presumably described in the pilot's handbook, but that is something of a guess, because when I picked up the airplane they had no handbooks, and have never sent me one.

**ED:** Furnished a list of problems encountered with the Robertson folks relating to having his plane ready when they promised. The long and short of it was they took almost three weeks longer than was originally anticipated. There were some difficulties which were corrected satisfactorily and there were some that were not. All in all, a great 400 was made even greater with the STOL conversion.

## HOERNER WING TIPS

We were just turning final. I reduced the power to 15 inches and my 180 Comanche slowed down to 65 - 70 mph indicated. Over the fence, I pulled the power and pulled back on the yoke. Suddenly my left passenger called out, seat "Watch that airspeed - we're below 60!" At 50 - 52 indicated, we sank to the runway to the accompaniment of the familiar squeak of a perfect landing.

Marc, my trusted radio man, flying left seat to check on a radio problem could not believe that we had not simply fallen out of the sky 50 feet above the runway. The answer - Hoerner wing tips.

It all began two years ago when I first met George Flynn at the Northeast Tribe Fly-In at Mt. Snow, Vt. George and his wife, Lucille, were very enthusiastic about their then new Hoerner tips.

Listen to what George told me:

"We purchased our Hoerner wing tips strictly on the basis of the Hoerner advertisements and also because we observed that Beech used that configuration on their Bonanza. Beech dropped it on the "P" and some of the "S" models and returned to it again. Cessna has switched also."

"We flew our Comanche 260 B for about 150 hours before converting. Frankly, I did not like the sloppy aileron response of the Comanche tips at slow speeds below 85 mph. 90 mph over the fence was OK but nothing to brag about and they were not sharply responsive in cross winds. I sold my old tips for \$50, so it struck me that an extra \$45 was a pretty good gamble if the tips did one-half of what the advertisement said. The price at that time was \$95. I was chomping at the bit to try them and the paint wasn't even dry when I took off about 400 pounds under gross with full tanks and two aboard. I whipped it into a sharp stall and all it did was hang on the prop with 12 inches and nice aileron response. Indicated speed was around 60 mph with gear and flaps up."

"Landings are a lot more comfortable. I now come over the fence at 75 - 80 mph indicated and touch down in a nice controlled stall at something around 60 mph. Short field landings are duck soup. Comanche owners on my field ask how I can turn off so soon. I tell them I never use brakes and they walk away talking to themselves."

"Speed was not a factor when I bought the tips. However, I am getting something more than 5 - 10 knots additional speed. I have flown along side a 1965 Comanche 260 B at the same power settings (23 square) and went by him at a pretty decent clip."

"All of which proves nothing to the purist. I am no physicist nor have I run definitive tests to establish absolutes under varying conditions. Nor do I intend to. And if it's all in my head, as some claim, that's OK too because the tips please me and perhaps add something to my 5000 + hours of flying and observation."

So after that salvo, I couldn't get hold of those wing tips soon enough.

The minute they arrived they were installed. That took less than two hours, by myself. And after they were signed off by the AI, four of us took to the air to find out what the wing tips had done to my 180 Comanche. Well, in a nutshell - everything short of a miracle. Stall speed is now around 50 - 52 mph indicated versus previously 60 - 62. There is plenty of stick shake for prior warning before the stall. All during the stall we have complete aileron control. That wing just refuses to completely stop flying. Departure, or power on stalls are a piece of cake. You will have to stand the shake for several seconds before the plane finally stops flying. Any tendency for a mushy,

over the top roll is quickly controlled and stopped with combined rudder and aileron response - the way it comes naturally. Just imagine what that means in heavy turbulence.

Simply stated, I would hate to fly a Comanche that did not have Hoerner wing tips.

## **HOERNER WING TIPS**

There were many reasons why we replaced the wing tips on 51 P. The main reason was the good reports that we heard about the improved low speed handling. With the various low speed aircraft operating out of our Long Island airports, slipping into the local traffic pattern in a fully loaded Comanche with a gross weight of 2900 pounds, 90 mph feels real comfortable. The J-3 Cub putts along at 60 mph so we do a lot of S-turning. And what about the student in the Cherokee? "Yep," that's right - he's climbing right up your tail. This is S.O. P. at Zahn's Airport. Now with the Hoerner tips I can slow old 51 P down to 70 mph with gear and flaps in the breeze and still have smooth aileron control. I will say that when I turn final I drop the nose and put the I.A.S. up to 80 mph just to have good positive control for a go-around if necessary. I don't make approaches behind the power curve. I keep the nose down until I have crossed the fence and then I let the speed bleed off and 51 P seems to aileron control right down through the stall.

There are claims that the tips give you 3 mph more cruise. Well at 65% power, I only get 180 mph at 8500 feet. Maybe 51 P is tired but Jill and I love our Comanche and to tell you the truth, the new tips look a lot better than the old Piper ones. Also, I think they make it easier to judge space when you are taxiing through a tight ramp.

I've only found one problem: the new tips add about an inch to the wing span which makes parking in some T-hangers uncomfortably close to the walls.

If you were to ask me if I would recommend the tips, I would say, if you must replace an original set at their going price of \$80 each, for \$110 you can have a nice new pair of Hoerner tips. Ed: The Hoerner tips can be ordered from Met-Co-Aire, P.O. Box 2216, Fullerton, CA 92633. Phone 714 870-4610. See their advertisement in the Flyer.

## **DROOP WING TIPS**

The question of droop tips has come up a couple of times and I would like to relate my experience with them. I ran a series of stalls with no flaps, full flaps, power off and with 10 in. MP. Then tried level flight at 75% power, then five landings and take-offs with the original tips. There were two of us in the airplane with full inboard tanks. I then installed the droop tips and did all of the above again plus flying about ten hours including landings and take-offs on the 1500 ft. field. I then removed the droop tips and re-installed the originals and went through all the flight tests again.

After averaging out all of my figures, I came up with a possible 1 MPH decrease in stall speeds, a 4 MPH decrease in level flight and a minute decrease in take-off roll. The only positive gain was a noticeable increase of aileron control at minimum speeds which helps in gusty wind approaches. My personal evaluation: they are not worth it and don't look very good.

## **DEMER SUPER WING TIPS**

With reference to the Demer Super Tips, I guess I'm a sloppy pilot because I never made real close, accurate checks with or without the tips. I did notice a couple things, however. There was

no noticeable increase or decrease in cruise, climb or stability. On landing, I felt it helped me smooth out my flare and touchdown somewhat. Worth the price? For me they made an excellent spot to paint the name of the WESTERN FLYER and the kids loved the "bat" tips at air shows.

## **INSTRUMENT PANEL MODIFICATION**

Surprised and grateful to hear from you so soon and that you plan a feature article on my panel. Following you will read as accurately as I can recall how it came about.

Sometime over three years ago I wanted to obtain my instrument rating but felt my old panel just did not fit any serious attempt at actual blind flying.

So questions arose. What are the chances of updating the panel to a more modern layout and at the least expense? Is it legal? Yes. Is a form 337 needed? Yes, and a field mod by the Feds should be okayed. Can I do it myself? Yes.

Planning to purchase a new radio and an audio panel I went to the local Piper dealer and struck an agreement that I would buy from them if they would provide me with help and guidance on my great undertaking.

I had had little experience with aluminum, but with riveting not at all. After taking thousands of measurements, making gobs of cut outs from poster board I spent many evenings bent over the drawing board. Since the radio gear was exhausting my funds no new instruments could be considered; besides, the auto pilot would need the present gyros. In the modern T arrangement the artificial horizon sits above the directional gyro. The original gyros are too big and fat for that so had to be side by side.

After many drawings things began to look better and finally suited me. After acquiring the aluminum needed for twenty dollars and a thirty five dollar hole cutter soon the panel was a reality. About that time the annual on Papa baby was due; the radio gear on hand, a date was set.

The first weekend I pulled everything out of the panel, cutaway the unneeded area, re-routed all wiring and piping, installed the shock mounts, bolted in the radio rack, attached the panels and went home exhausted. During the week the annual and radios were installed. They had to redo some of the radio rack area to make it stronger, and I was thankful to them for that. Saturday and half of Sunday I put everything together. Best part of any job is the assembly, seeing 'everything go together and soon it will be finished. The shop manager checked it all over, had me put some types here and there under the panel to make sure nothing could rub on the control cables and cause trouble later. About three that afternoon I went for my first flight. My I was happy, but where is the airspeed indicator? Oh there it is. Soon everything looked familiar to me and I felt very satisfied with myself and the panel.

Later, after finally giving up on the auto pilot never working most of the time I decided to get a Century 1 and a new style directional gyro. And feeling anything can be done better a second time a new panel was needed to accept the new D G. The new D G is lots smaller than the old one and everything can be more closely arranged and will look even better. I like the old style artificial horizon and decided to keep it especially since it had just been overhauled. Also it got me through my instrument instructions and check ride, I'm rather fond of it, I've looked at it so much. For that factory fresh and professional look I had the new panels anodized black.

Spent an evening at the dining table and put on all the placards with rub-on letters, sealed them and installed the panels. I'm satisfied now.

This finishes the story. About the time needed to do the job. For me it was considerable, for a lot of time was used just planning it out. Still have discarded drawings scattered about. It was a labor of love and was one that I would do again if not just for the fun of it, then I feel safer while instrument flying with everything where the good Lord intended and not scattered all about as the original was. Incidentally, I gave the original panels I made to a fellow Comanche flyer. Have had no contact with him so do not know if he ever tackled it.

As I think I mentioned in my last letter, I had blueprints made from my drawings and will send one with a picture to any brave soul wanting to attempt such a hard but rewarding task. If enough requests for the first panel using all the old instruments are forth coming, I will ink in those drawings and have prints made.

**ED:** Frey's panel drawings are available from ICS headquarters. We regret that Ray is now deceased.



- 1. Air Speed
- 2. Directional Gyro
- 3. Artificial Horizon
- 4. DME Indicator
- 5. Altimeter
- 6. VOR w/Glide Slope
- 7. VOR
- 8. Turn & Bank
- 9. Clock w/a Second
- 10. Suction
- 11. Digital Clock w/Timer
- 12. Climb
- 13. EGT
- 14. ADF

- 15. TACH
- 16. CHT
- 17. HOBBS
- 18. M.P.
- 19. Carb. Temp.
- 20. Fuel, Fu. Pr. Fuel
- 21. Oil Pr. AMM Oil Temp.

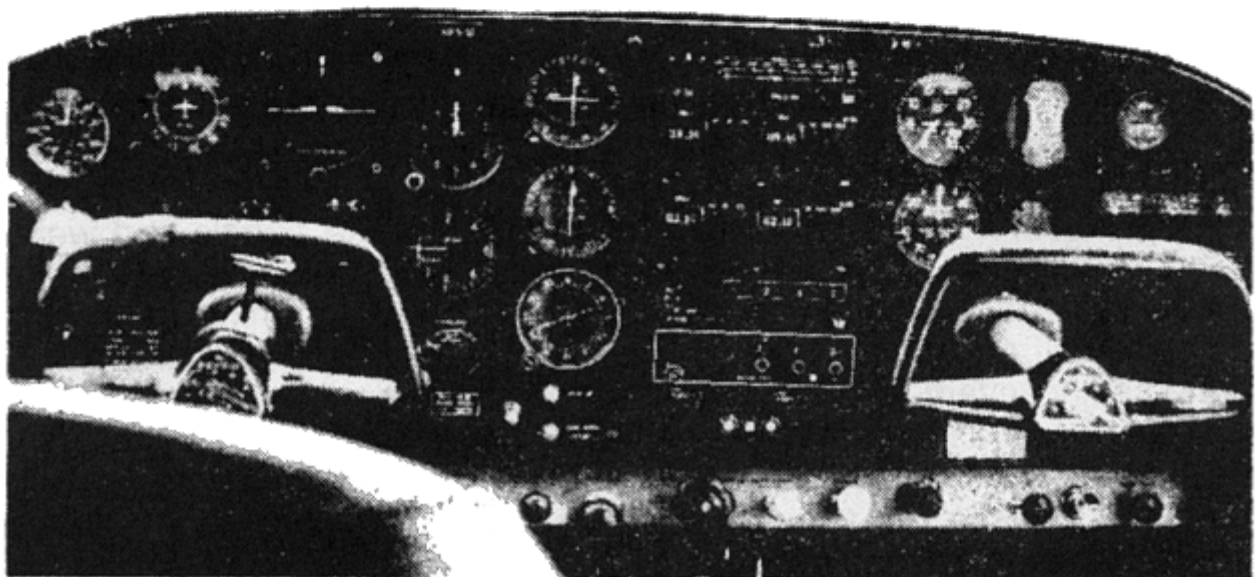
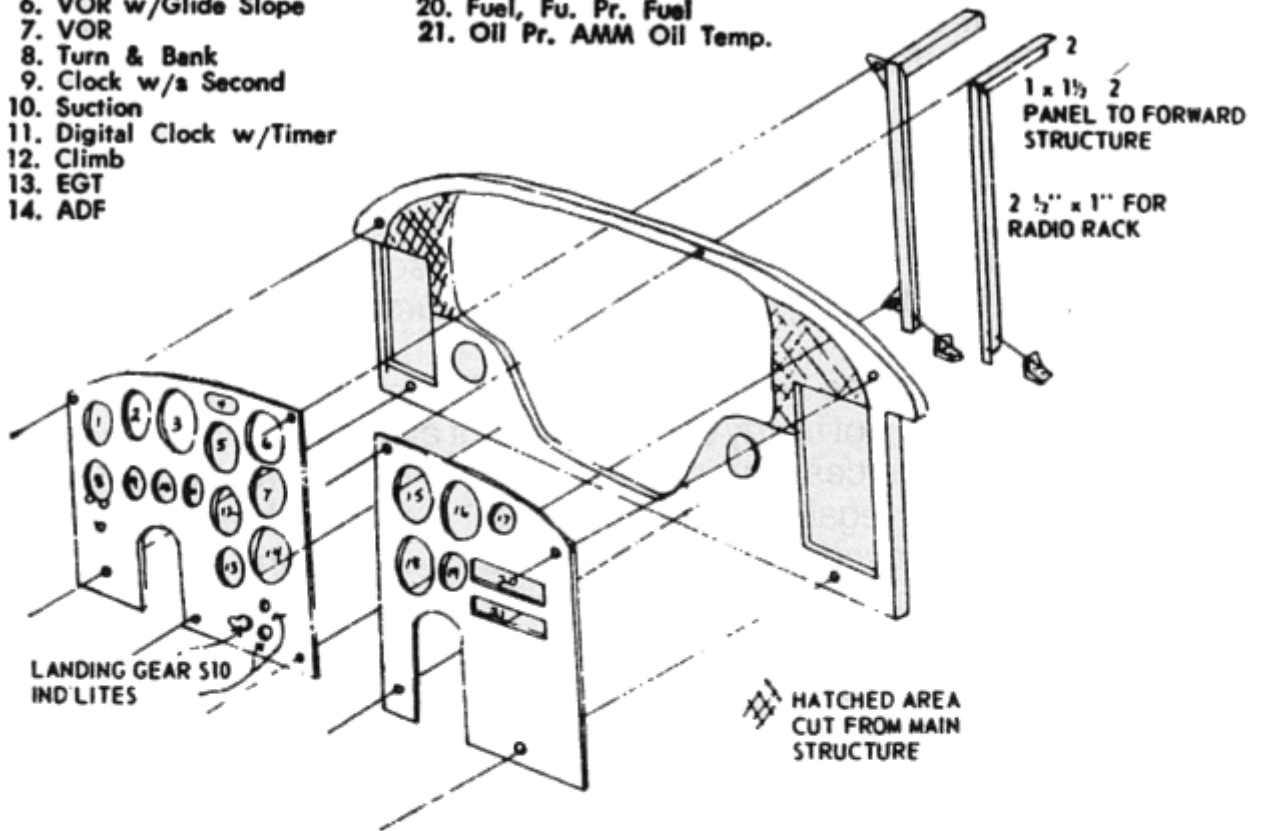

## TWIN MODERNIZATION

I'm on my second Twin Comanche now. The first one (N7090Y) was bought new and gave me five years of trouble free fun and transportation.

While considering the purchase of another airplane last year, I evaluated not only the other aircraft available but my recollections of the good and bad things that are inherent in the Twin Comanche. I concluded that as good as a standard Twin Comanche is as a personal airplane, I wanted some thing better in engine out performance and more safety in difficult situations. I finally decided to buy a Twin Comanche with the modifications that were available. The good things about a standard Twin Comanche are so incredibly obvious - adequate speed, exceptional economy, unusual quietness, etc. The "bad" things are only those things that are relative to other light twins "average" single engine performance, "average" single engine ceiling, "average" useful load, "average" interior room, etc.

My present Twin Comanche (N7830Y) is a blend of the factory product and those modifications available for the aircraft. This blending has produced a machine that I find difficult to fault.

These are the modifications on N7830Y and my views on each:

### A. All the Miller modifications except the turbochargers were installed in 1976;

They are:

1. 200 HP normally aspirated engines. This increased both speed and climb. I get 175 knots true at all altitudes up to 10,000 feet MSL using no more than 75% power. Single engine ceiling is about 11,000 MSL at gross. Climb at gross is 1500-1600 ft/minute indicating 125 knots. At any given airspeed the fuel economy closely matches that of my first Twin Comanche. Noise level is slightly higher with the Miller Conversion.
2. The Miller nose with baggage compartment was added as well as the nacelles which also have baggage compartments. The nose baggage area stays dry no matter what. The wing lockers are waterproof in flight but not on the ground. "Yes" on the nose, "No" on engine nacelles.
3. A Miller one-piece windshield was installed, and in my opinion, is worth every penny spent. (Now available at lower cost from other sources).
4. Super-duper Aztec brakes were fitted. Absolutely incredible - a case of "overkill" I suppose, but nice if/when you need them.
5. The Miller "wet wing" aux. tanks were installed giving. 19 gallons per wet wing side. They are nice.
6. Some other items were added such as the nose wheel taxi light, etc., all of which are nice to have.

### B. The Ultimate Mod:

The Robertson STOL conversion was added after all the above and it has to be the answer to all the handling "problems." It is, in my mind, the single most desirable (necessary) modification available (160 HP or 200 HP - I've flown both). Contrary to what one might think, it does not reduce cruise speed at all while allowing positively insane maneuvers in an engine out / slowflight situation. After the installation, Henry McKay of Robertson gave me several hours of instruction / demonstrations leaving me with the confidence that the airplane cannot get you into trouble unless you deliberately aim it at an immovable object. In

addition to the safety inherent in the conversion, the Twin Comanche can be landed as easily as a Cherokee which is a nice bonus.

There is no question that all these additions and/or modifications to the plane are costly and if I had a bare Twin Comanche - knowing what I know now - I would opt for the Robertson STOL first, the windshield second, the Aztec brakes, third, the nose baggage fourth, the 200 HP fifth, etc., etc.

I cannot comment on the turbocharged Miller as I have never flown in one, but for you speed buffs - side by side with normal Barons 31 0's or the like, I'm a little faster regardless of what the needle on their airspeed indicator shows.

## **HOSKINS COMPUTER FUEL FLOW SYSTEM**

I'd like to tell you about an instrument I just installed on my Comanche 260B, the Hoskins Computerized Fuel System.

Recently my company purchased an Aztec which already had the CFS installed. At first it seemed like a space age electronic gimmick, but as I used it, I was impressed by the incredible accuracy of the unit. If the tanks were topped and the aircraft flown until the DFS read 31 gallons burned, and the tanks topped again, 31 gallons is exactly what it took. Adjustments of 25 rpm or a slight movement of the mixture barely noticeable on the EGT would instantly show up as changes in the fuel flow with attendant fuel savings. Individual fuel tanks could be run down to one gallon remaining and then switched. Running tanks dry to get the last drop was no longer necessary. Range in hours and minutes at a given throttle setting was displayed with complete accuracy as was gallons/pounds used and remaining along with a very precise timer.

After several weeks of use in the Aztec (Aztec gauges are as inaccurate as Comanche fuel gauges), I decided to get one for the Comanche, but found that they weren't yet approved. I allowed Hoskins to use my 2606 as the STC aircraft. Now that I have it back, I'm just as pleased with unit as I was in the Aztec. I have arranged through a local distributor to get a club discount on the CFS, so if any ICS members are interested, we can get the CFS at a substantial discount.

## **TWIN PERFORMANCE**

This is a 1970, PA-39, Twin Comanche, turbo charged CR with the following modifications: Robertson Safety Kit, Miller extended nose, wing lockers, nose gear light, one-piece windshield, double thickness double pane side windows and new paint of gold, red and white polyurethane.

Although the Robertson modification provides some STOL characteristics, Robertson prefers to call it a Safety modification for the following reasons slower takeoff and landing speeds, lower stall speeds, and better single engine climb capability which was our primary objective in this change.

Consider the performance differences for the PA-30 at 3600# gross, the PA-39 with an original gross of 3725#, and now 3800# with the Robertson to visualize the advantages of the safety modification.

	PA30 3600#	PA39 3725#	PA39 3800#
Vmc (mph)	90	80	75
Takeoff run (ft - short field)	1250	990	520
Takeoff distance (ft) over 50' obstruction	2160	1590	1050
Stall speed (mph - gear and flaps down, power off)	69	70	63
Stall speed (mph - clean, power off)	76	76	67
Accelerate - Stop distance (ft)	N/A	2560	1310
Single Engine climb rate (fpm)	260	165	305
Best SE climb speed (mph)	105	105	90 (15° flap)
Landing roll short field flaps down (ft)	700	725	590
Landing over 50' obstruction short field, flaps down (ft)	2100	1900	1165

These performance figures are all based on standard temperatures of SL and can be accomplished by a competent pilot where short field ability is required, but are not realistic in every day operation. As an example, Piper's Twin Comanche "C", PA- 30 handbook specifies a flap setting of 15 for takeoff, lift-off speed of 80, and obtaining 91 MPH at 50'. Robertson uses a speed of 60 to commence rotation, lift-off speed of 70, and 75 MPH at 50'. In all cases lift off speed is below VMC which is not safe unless the pilot is prepared to immediately retard the other throttle in case of engine failure below VMC. In addition, Robertson indicates that in the standard Twin Comanche at least 250' will be lost while "cleaning up" the airplane and accelerating to 105, best SE climb speed. However, the Robertson at a certified gross wt. of 3600 lbs. will climb on one engine at a considerably better rate at 90 MPH with flaps 15 than the PA-30 or PA-39 clean at 105.

I can substantiate to some extent Robertson's climb performance before we installed their modification. One hot summer day with a density altitude of 5000' over the Calif. desert, we made several take offs with two of us aboard, 120 gals. of fuel, with gross wt. close to maximum and simulating a power loss on one engine at approximately 50' above the field and indicating 90 MPH with the gear and flaps up. At no time were we able to accelerate or climb until the turbo was brought in. Only then were we able to increase speed and climb rate.

During operations out of short fields, I consider the accelerate-stop distance to be the most critical of any of the parameters and here the Robertson really shines, although again, the 1310' may not be realistic as I don't know whether they are using 60 MPH, where they begin rotation, or 70 MPH as liftoff speed for the take-off decision speed. In either case, there is a significant decrease in the distance required over the standard Twin Comanche.

Regarding the Miller conversions, we didn't experience any increase in speed or performance with the extended nose or wing lockers, but they add a good deal of useful space, contribute to a more comfortable traveling machine and enhances the appearance of the aircraft considerably. Probably the best of these conversions were the one piece windshield and the nose gear light. The light fills up the dark hole between the wing lights when landing at night and by having an unobstructed view through the windshield we have a better scan of the horizon.

The Miller 200HP engine conversions would be nice for more speed and a much better SE climb rate, but I prefer the reliability and economy of the 160 HP engines.

To sum up, we flew and enjoyed a 250 Comanche for 5 years while we looked for a low time factory equipped turbo CR and since there were only 155 CR's built and not many of these were turbocharged we didn't have many to choose from. The Robertson fulfills our requirements for accelerate-stop and SE climb performance, but we have lost 5-6 MPH at cruise speeds. Also the flight characteristics are completely different in this respect; good aileron control at extremely low speeds and the aircraft can be flown off or onto the run way on the stall buffet where the standard Comanche has a tendency to "drop out" from under us at low speeds.

In the July, 1975 Flyer I wrote about our high altitude take-off tests with the Comanche 250 and also commented that I couldn't detect any difference in cruise performance with the tip tanks. I also find this true with our twin when comparing power settings and cruise speeds with the PA-30 charts for aircraft without tip tanks.

To the best of my knowledge there has not been any production light twin built in the past or being built today that matches the speed and efficiency of the Twin Comanche. This particular airplane has a speed range from 63 MPH at stall to 235 MPH at altitude and can operate from virtually any airport in the U.S. To make a long story short, a beautiful airplane and a dream to fly.

## **TACHOMETER Digital tachometers now STC'd for Comanche.**

**Q.** How can I get a better RPM indication on my PA-30. Seems to me that a digital unit such as is available for cars would do a better job.

**A.** The tachometers on the PA-30 are manufactured by AC (General Motors). They are designed and operate just like the speedometer on a car but read in RPM rather than MPH. They are not very accurate but can be adjusted to be reasonably close within a narrow range. The hour meter is an RPM counter which adds up approximately one hour when the engine(s) are turning at normal cruise with the tach set for that RPM.

The tachometer cables are long but not as long on this airplane as on the Aztec. When they are kept properly lubricated, they give no problem. Basically, it is a good system, as they cost much less to purchase and they are easier to maintain than the more sophisticated tach gen / tach systems.

The ultimate fix is a twin tach unit which is a dual instrument of high quality. I believe these were developed and manufactured by Consolidated Instruments out of Teterboro, New Jersey. This tach has a hair spring drive inside the unit to dampen any slight whip or oscillation from the cables. You will find, with the engines synchronized, that both needles will read the same anywhere within the range.

These tachs can be purchased at your Piper dealer. An extra benefit to going this route is it gives you an extra 3 1/8" hole for some other instrument.

The only negative point is that an hour meter will need to be installed. This is necessary to record aircraft and engine time. This also can be obtained from your Piper dealer who can install it in your aircraft.

## **ONE PIECE WINDSHIELD INSTALLATION**

**Q.** Who makes one piece windshields for the Comanche? What are the problems in getting them installed? Does it take any special care or knowledge to get a proper fit. Are there any other considerations?

**A.** With regard to the one piece windshield for the PA-24, PA- 30/39, there are a number of manufacturers. The following are a few:

1. Great Lakes Aero Production of Flint, Michigan
2. Wayne Air Frame in California
3. Miller Aviation, Horseshoe Bay, Texas
4. Berley Aviation, Newton, Kansas
5. Cee Bailey in California

On the merits of tinted vs. non-tinted, Bill Turley, owner of Aircraft Engineering, Rt. 3, Box 246, Bartow, Fla. 33830, who has made many of the installations advises to use tinted only.

The windshield can be installed in a local shop if the personnel are accustomed to this type of operation. If you select the windshield made by Great Lakes Aero, it is my understanding that only a small amount of trimming and fitting is necessary. However, it is no easy job to fit the collar around the bottom and have it look proper. However, it can be done.

The outside air temperature probe can be mounted easily just forward of the vent window.

The best place to mount the compass, in the very top of the windshield on a short portion of the center brace left on for this mounting. Otherwise, this would be sawed off flush at the top.

In the matter of a one piece windshield, there are advantages. There is better visibility as the center brace is removed and there is quieter operation because of the 1/4" thickness. See above for information on the windshield.

## **ROBERTSON STOL MODIFICATION**

We operate a 1967 CR Turbo Twin Comanche with a Robertson, and agree that it greatly improves handling characteristics, particularly at low speeds.

However, we find we have a speed loss of about 10 mph at cruise since the Robertson conversion.

Another "quirk" in the Robertson STC with Comanches having tip tanks is that the 3800# gross is not legal in all loading configurations. The last 125# must be fuel loaded into the tip tanks only. We explored this with Robert son as their publicity used to state that the 3800# gross is available in all flight configurations.

## **AD 79-20-10, AILERON NOSE RIB CRACKS**

This is a quick sketch of the problem I called you about. The sketch shows the problem I had with the new aileron nose ribs. There is no reason to believe that Piper didn't build quite a number of these at the same time and they would all be alike, especially since all four parts I received were the same. I didn't discover the problem until the ailerons were disassembled and the new ribs riveted to the spar and skin riveted back on. I haven't contacted Piper about this and when I do I expect them to pay for replacing these defective parts. I suspect that a lot of

these have been installed with the same problem and not recognized. I suggest some careful measurements be made before disassembly of your aileron.

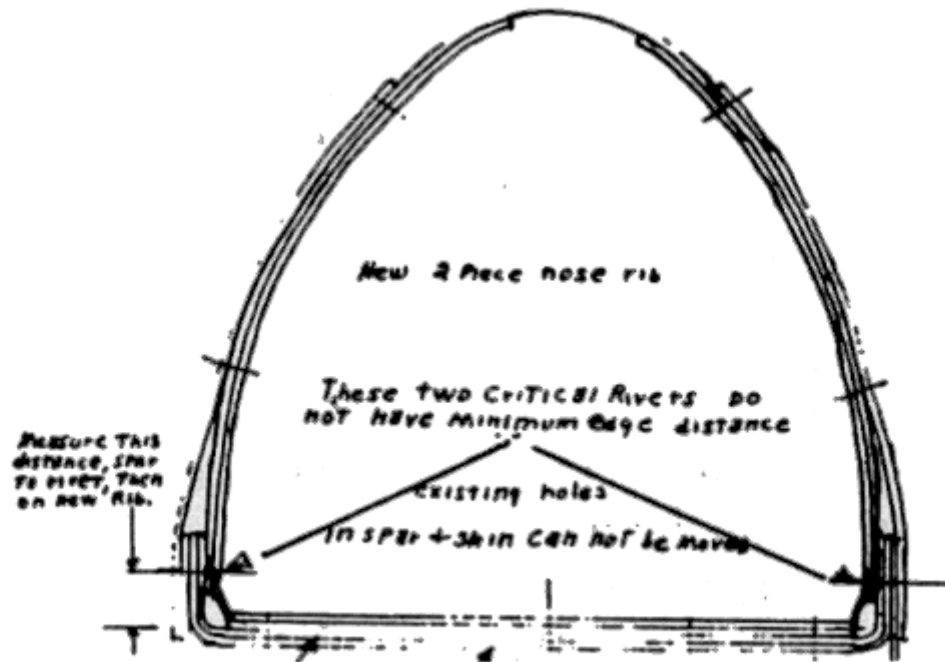

**ED: This ad and Piper Kit 763-893 solved this problem.**

## TIP TANKS

We put tip tanks on 4 years ago. Made by Osborne Tank and supply out in California. Osborne people are very helpful and easy to deal with. Total installation cost about \$3,150. Labor bill was about \$1,650, partly due to installation of a strobe at the same time.

Now carry 90 gallons and don't know how we got along without them. Can now go a full 5 hours IFR with our minimums. Plane will go approximately 7 - 7 1/4 to dry tanks. Our tanks are nowhere near that big. STC ups gross weight by 200# so only about 10# is lost from useful load.

Claims are made for faster cruise. Would guess it is worth up to 5 MPG. Always got there fast enough before, now its just a little quicker.

## AILERON AERO-TRIM SYSTEM

I recently had the Aero-Trim aileron trim control system installed on Ole Yellowbird, and have now accumulated enough operating time to be able to make an objective judgment on its value to the Comanche owner.

Most of my trips are business related with the majority of flight lengths running from 3 to 5 hours (single pilot, no autopilot & mostly IFR). Having the factory installed auxiliary tanks out on the

wing makes constant tank switching a necessity in order to maintain lateral trim, with the attendant wear and tear on the fuel selector valve.

One day I had the opportunity to fly a Cherokee Arrow that had the Aero-Trim installation and was immediately sold on the apparent usefulness of this device.

Now that I've used it for awhile, I don't know how I did without it.

As soon as I get the bird trimmed out at cruise altitude, my standard procedure now is to switch to my left aux tank till it is almost dry, trimming for wing heaviness with the Aero-Trim. I then switch to the right aux tank, etc., etc.

The only effort necessary to keep the wings straight & level is to just occasionally touch the trim switch which is conveniently panel mounted (See Fig. 1)

From an operational standpoint, it has made long cross-country trips a pleasure. For those -of you that have tip tanks, this system should be a must.

Fig. 2 shows how it is mounted on the bottom of the left aileron. The only surgery required to install it is the necessity for a square cut-out in the aileron, the wiring going thru the wing to the panel-mounted switch-indicator.

The installation took my maintenance facility about 4 1/2 hours plus the time I spent removing and replacing the seats and side panels in the cabin.

The installation kit comes complete with the indicator, actuator assembly and a complete set of instructions and template information, and requires the execution of a Form 337.

Complete information can be obtained from the manufacturer, Aero Trim, Inc., 1130-102 Street, Bay Harbor, FL 33154. Their phone number is (305) 532-2722.



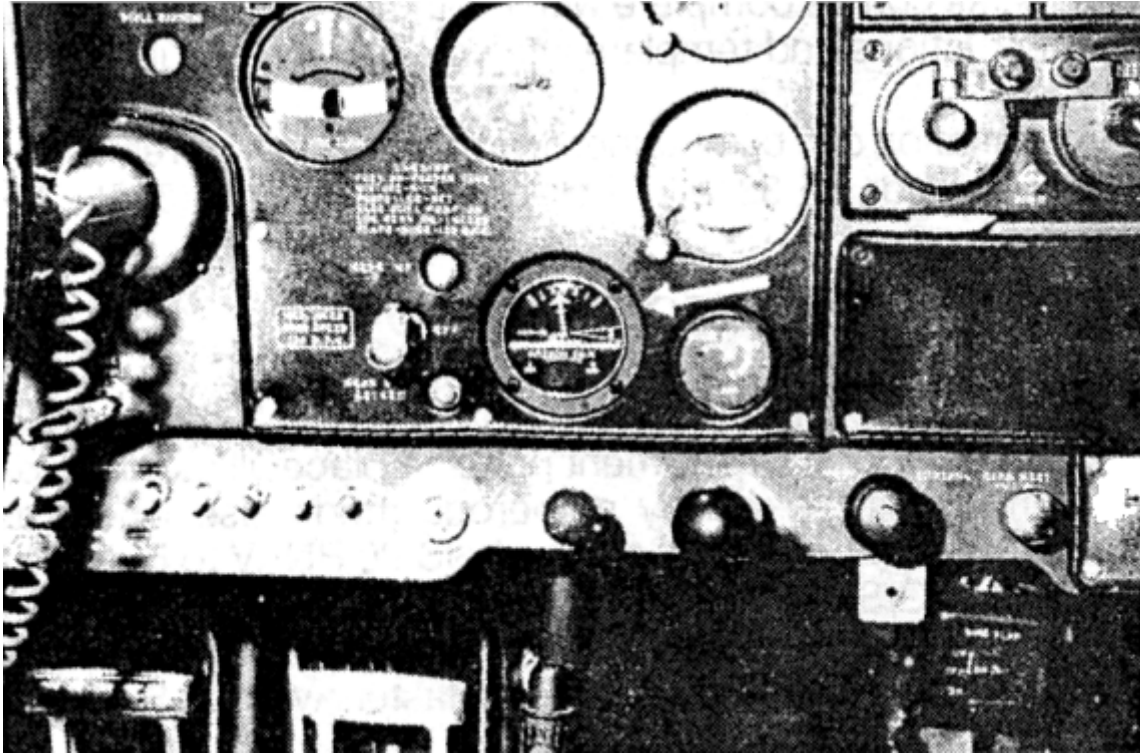

Fig. 1

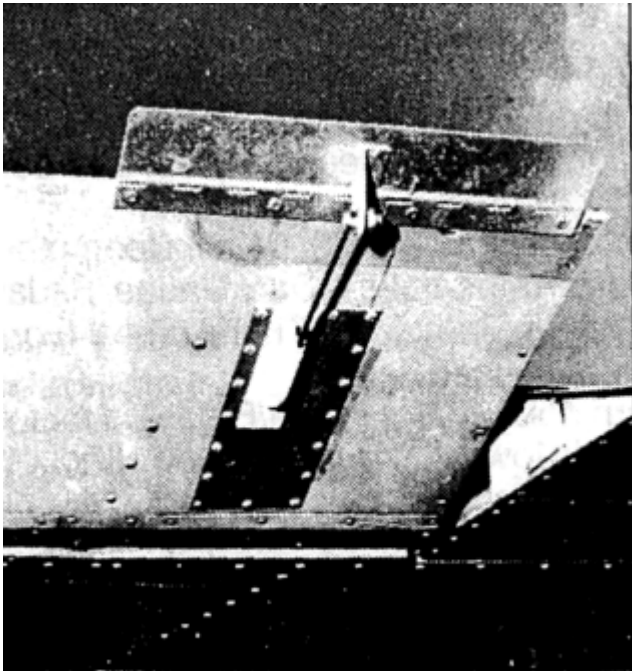

Fig. 2

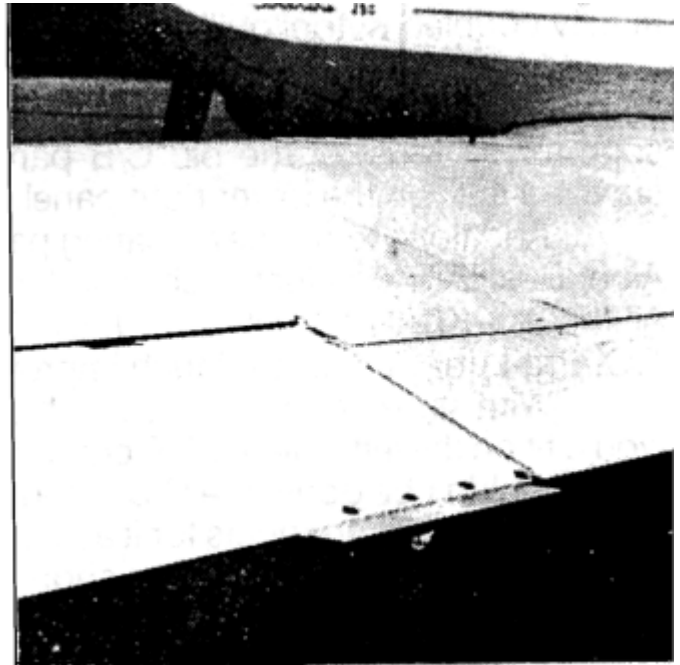

Fig. 3

## GAP SEALS

I would like to take this opportunity to write you regarding a recent modification made available' by Jim Bradshaw through his "Knots 2 U" company located at Wilmette, Illinois 60091, phone 312-256-4807, which specializes in an STC modification for the Twin Comanche.

I recently had this modification completed by Mr. Bradshaw's installation service, General Aviation Corporation in Janesville, Wisconsin, phone 608-752-4220. Dick Sullivan is the man to contact for installation.

The modification that was performed on my plane, Twin Comanche N7148Y, included flap, aileron, and stabilator gap seals. This lowered the stall speed and improved the speed, rate of climb and, most of all, the plane's basic handling. The plane is much easier to land with full flaps, without the usual problem of having to worry about the nose wheel dropping in before the main gear. It only took a few take-offs and landings to redevelop my technique for repeated smooth and controlled landings. The plane also begins to fly between 70 and 75 MPH and wants to leap off the ground even though I pull it off at 90 + MPH. In flying, the plane is much more stable. For instance, when performing 30 + degree banks, the plane maintains altitude very well without continually having to rework the trim.

The workmanship of General Aviation Corporation was excellent and performed with great care. The modification cost \$1,095.00 and was well worth the money. I believe that you should point this out to your readers. I am sure that Jim Bradshaw will be completing other interesting modifications that will help make the Twin Comanche a faster, better handling, much safer plane.

## **TWIN Q-TIP PROPS**

Many Twin Comanche drivers have been asking about the availability of 'IQ' tip props for their bird. Now, after almost three months of testing, the FAA has issued STC #SA557GL for the 'IQ' tip props on the PA-30 and PA-39. Many times during the tests my concern for the reliable old bird was challenged, as repeated full bore climbs were initiated from 300' AGL to 5,000' AGL then right back down to 300' for another run. Eighteen in a row were completed at one point with a fuel stop in the middle to keep N887UP at gross. Actually, all tests were conducted at starting weights above gross so an average could be found.

Actual performance changes will not be available for some time as the FAA was only concerned with the integrity of the propellers and need to incorporate flight manual changes if performance was below published numbers, to which there will be no changes. I can, however, report my personal observations:

1. Noticeable decrease in noise level, especially at take-off and climb (actual DB readings will be completed by the time you read this).
2. After three months and approximately 100 hours of flying into all kinds of strips, no leading edge prop damage at all. This, of course, is due to a complete elimination of tip vortices.
3. An increase in 75% cruise speed (two to three knots at least).
4. Increase climb performance.
5. A real shin-buster if you're in a hurry checking fuel level. All in all, I think those who elect to make the conversion will be pleased.

If you want more information, call me at (513) 890-1924 or write to Universal Products, P.O. Box 519, Vandalia, OH 45377. Hartzell Propeller Co. of Piqua, OH, is the only authorized agent for "O" tips and Bob Long should be called for scheduled and current prices. His phone number is (513) 773-7411. Propellers must be standard 72" prior to 'IQ' tip and exchanges are available.

## MET-CO-AIRE WING TIPS

The wing tips were warped with age so I decided to replace them for cosmetic reasons. The increase in performance has been appreciated as I operate from a 1900 foot runway with obstacles at both ends. The take off run seems to be shorter and I cross over the wires higher than before. When landing, I now hold 70 MPH till over the wires then take off the power and settle to the runway with room to spare. There is good aileron control till she stalls out at an indicated 3 to 5 MPH slower than before the new tips. Thanks to the letters in "Comanche Tips", I selected Met-Co-Aire Tips and they are superb.

## GAP SEALS

- A. I recently had the Knots-2-U Gap Seals installed and am quite satisfied with the results. Previously, at full throttle and 2400 RPM my TAS would work out to 176 after leveling at a typical en route altitude of 7000' with a full load. I carry 90 gal. and after a couple hours of fuel burn the TAS would eventually work up to 180. Now my initial TAS is about 184 which increases to a solid 188 as the fuel load is burned off. On a recent trip to Florida I tried 192 at 7500' for the last half of the flight southbound but it hasn't happened since. I am confident, though, that 6032P is 8 MPH faster. In addition to the speed increase, the handling is much improved - particularly during landing. Roll response is better and 32P seems to settle gently through the flare for a softer touchdown at slower speed than before when it would occasionally quit flying and drop the last inch or so. I also think we climb faster now but I have no figures to verify this. All in all, the mods make a great airplane even better.
- B. I had Knots-2-U perform their modification to my 1972 "C" Model Comanche 26 December 1981 in Janesville, Wisconsin. Prior to my departure from Upland, California, I checked the Pitot / Static system for leaks, the Airspeed indicator for calibration, and the Davtron Digital OAT for accuracy.

While en route to Janesville, Wisconsin I made several TAS / IAS / Temp. / Altitude records. After the modification kit was installed I then made records at comparable altitudes and temperatures, all the time using the exact same Manifold Pressure and Tachometer settings.

The speed increase or difference before and after modification amounted to 5 MPH between 5000' and 9500' ASL. While this is not as much of an increase as expected, the low speed handling characteristics improved 100%, landings now are ALL "Squeakers" loaded or empty and the rate of climb improved by 200 to 300 ft. per minute.

I have again checked the Pitot / Static / Airspeed systems after returning from Janesville and found no problems. I called Mr. Bradshaw and inquired as to why the very low improvement in speed, he suggested that possibly the Gear Doors were protruding and offered to pay for having them checked. I had the entire Gear system checked by our local maintenance facility, everything normal. I elected not to take Mr. Bradshaw up on his offer as I feel that isn't his fault. Trying to improve the speed on an already fast airplane sometimes doesn't happen. I am well satisfied with the job and it was well worth the money just to obtain the ability to now be able to "squeak" it on every time similar to a Cherokee 140. No more embarrassing "Thunkers" once in a while. Of course, the dramatic increase in climb is another nice side benefit.

## **TURBO RAJAY KITS**

While at the Piper factory yesterday, I did some research regarding this question of Mr. Metzger's about the turbos. According to his letter, he saw in the Flyer something about putting these on a 260B. Not so, from what I have been told.

The STC #SA-2062-WE is in Rajay's name but the rights belong to Piper as they paid them to get approved. This is on the Lyc 10-540 RIA5 engine only. It is for C models only and starts with S#24-4804 up.

Bill Black is the most knowledgeable about Comanches of anyone I know at Piper and I get this from him directly. He has been promoted and in a completely different job now but sat down to go over this with me. He also warns that the installation is costly to the point of being almost prohibitive. It requires an engine change, a complete exhaust system change and many other \$\$\$\$\$\$ changes. To my knowledge, there is no kit so it would be necessary to get required parts from the drawings.

This information does not even apply to his aircraft but possibly he knows someone who has done it so he may have more knowledge about it than I do.

## **BRAKES REPOSITIONED MODIFICATION**

While I was at General Aviation Corporation at Janesville (they are the maintenance facility that actually does the work when you have a Knots-2-U mod done), I also re-installed my brake mechanisms inside the wheels. A tiny notch must be cut in a small auxiliary rib to clear the little block at the front edge of the caliper assemble to which the brake hose is attached - otherwise, the brake just bolts on the other side without any fuss. (I have the two-sided forks - if you have one-sided forks, you must obviously swap them from one side of the airplane to the other.)

I don't think the brake change really does anything for speed (Jim Bradshaw and GAC folks once worked up a full fairing for retracted Comanche gear and found that it did virtually nothing for speed; apparently, the wing under-surface is not a very critical area) but it does get the caliper, disc and hose out of the weather while flying, and it's very easy to do.

## **FUELTRON COMPUTER FUEL FLOW SYSTEM**

I am an owner of a Twin Comanche which has installed in it the Silver Instruments Fueltron fuel computer system along with a comprehensive IFR avionics package which includes a KNS-80 RNAV. The Fueltron has been such an outstanding piece of equipment that I have intended telling other Comanche Society members about it. This letter is prompted by Tom Smith's article in the February '82 issue. I am concerned about the legality of Capco's installation, but more on that later.

Using the Fueltron, I have been able to save considerably on fuel consumption and obtain some impressive range stretching performance. The range stretching has often been when using the highly accurate time remaining feature of the Fueltron in conjunction with the KNS-80 ground speed and time to way-point displays.

The Fueltron has proven to be quite simple to operate. I must enter the starting fuel quantity, but the instrument's design makes this very easy to do. If the tanks have been filled or if no fuel has been added from the previous flight, I simply flip a switch to "FULL" or "NONE" and press the Reset button. The proper fuel amount (programmed into the unit at installation) automatically

appears in the Fuel Remaining display. The instrument's memory retains the amount of fuel remaining from the previous flight. Adding partial fuel requires the use of an additional switch, but the procedure is like setting my digital watch. Silver Instruments, the manufacturer, claims an accuracy of one percent for the Fueltron's digital display of Fuel Flow for each engine, Fuel Remaining, Fuel Burned, and Time Remaining. This must be true because I win bets from the fuel boys on how much it will take to top off the tanks. I have found the performance to be sensitive enough to indicate partially clogged fuel injectors and some other obscure engine problems, most recently, retarded mags on one engine.

One of the things that has really impressed me about the Fueltron is its quality. The unit has been 100% reliable in over 800 hours of flying by "ham-fisted" rental pilots. Silver Instruments states that their field experience over the five years that the current third generation model has been produced shows a mean time between failures of at least 4,000 hours. This must be true since most of their fuel computer business is for factory installations in aircraft costing 1/2 million dollars or more.

I do have two questions, however, regarding the Twin Comanche installation. When my Fueltron was installed it was required by the STC that the old pressure type fuel flow gauge remain in the airplane. Tom Smith's article and Shadin Corp. ads in recent issues of the Comanche Flyer indicate that the flow gauge could be removed. I asked Silver Instruments about this as I need another hole in the panel. They said that the FAA requires the Lycoming engines have fuel pressure gauges installed. This is because the engine-driven fuel pump is an accessory and is not certificated as an integral part of the engine. Since the original Piper fuel flow gauge is really a pressure gauge it serves both functions. Silver Instruments stated that the FAA quoted Sections 3.449 and 3.672 of the Federal Air Regulations in requiring that the old flow gauge stay in. Since that appears to be an FAA requirement then it must be illegal to remove the old fuel flow gauge when installing an electronic fuel flow system.

Now for the questions:

1. If removing the OEM fuel flow gauge is illegal according to the FAA in California, why is it legal in Minnesota?
2. If there was an accident, could the insurance company use this apparent FAA inconsistency as a reason for not paying a claim?

Tom Smith should be commended for offering a good deal on a useful piece of equipment. I suggest though that the installed prices be compared and the specific legality of the Capco / Shadin STC be reviewed, especially if the aircraft is used in rental or part 135 operations.

I just received, as I was typing this letter, the May issue of the Comanche Flyer and noted Jim Scott's letter. Beware of the airplane application of automotive fuel flow gauges. The ones I've seen use plastic transducers held together with screws, and can be stopped up by a piece of dirt in the fuel. I can't see how they would ever be approved by the FAA, and an STC is required to install the transducer in the fuel system. The aircraft types are FAA approved. By the way, the Fueltron is made by Silver Instruments.

**ED:** The FAA Seattle modification branch sent three men, including the head of the branch, to meet with Capco / Shadin and after much testing approved their STC after finding a "degree of equivalent safety". This multiple STC 1431 NM approves the optional replacing of the old original gauge and is good all over where the FAA has authority for the PA-30 and 39 series. Their STC 1497NM approves the same type of application for the PA- 24 260. When questioning Tom Smith about this he also stated that when the STC for the carburetored 250 (expected in July) is

issued the small pressure gauge must remain as there is no fuel flow gauges to pull in that series.

## **FIREWALL FUEL AND OIL LINE MODIFICATION**

### **Applicability:**

All Piper PA-24 / PA-30 series aircraft incorporating through firewall fuel or oil line routing not utilizing flared bulkhead fittings for transition.

### **Subject:**

To preclude in-flight leakage of pressure fuel or engine oil, and to reduce the possibility of in-flight engine/cockpit fire, inspect and replace as necessary engine to instrument cluster fuel and oil pressure lines.

### **Compliance:**

Prior to next engine start and further flight. This RD is effective immediately upon receipt.

### **Discussion:**

Wiring, control cables and engine instrument lines are often routed through the fuselage/engine compartment firewall by means of an opening in the firewall (later designs incorporate some bulkhead fittings where applicable). To prevent chaffing with the steel firewall, cables, etc., are supported by the two mating halves of a fire resistant material - generally rubberized asbestos - in which holes of appropriate size are provided for passage. This material is then held together by the two sides of a sandwich clamp affixed to the engine side of the firewall. Each combination will accommodate one, two or three cables, etc., depending on the individual diameters required. The center material provides firm, but not abrasive, support, and a portion of the required air/liquid seal. Anti-vibration support and positive seal are accomplished by forcing an appropriate "putty" around each individual cable, wire bundle or line, at the sandwich support, then, with additional putty, building this up to form a rounded dome that completely covers the support material.

Putty that has been in place for a long time may become hard or brittle, due to age and engine heat, and break off. It can also be easily displaced during maintenance. Resulting vibration will cause chaffing of the affected through lines. If a crack in a pressure fuel line develops, raw fuel will be pumped into the cockpit and/or engine compartment. Depending on the location of engine exhaust components, the potential for in-flight fire is extreme. A crack in the oil pressure line may be of similar concern. Either event while in flight would require immediate pilot action.

### **Method of compliance:**

With cowling open or removed, remove all putty (or other sealant) from each through-firewall sandwich support fitting. Clean lines, cables, wiring, etc., of all sealant and inspect for chaffing, crimps, cracks and other damage. Inspect condition of supporting material in sandwich clamps. Replace components as necessary. Note: If a fuel or oil pressure line is noticeably chaffed or crimped, replace entire length of line. (Removal of a good sandwich clamp can be avoided by feeding the new line through the firewall from inside the cockpit or nacelle prior to attaching the flare nut and sleeve and flaring the tubing end). Assure firm support then reseal with approved putty or sealant as described under "discussion", above.

### **Estimated cost:**

Negligible if you comply; potentially your life if you don't.

This notice is a result of our becoming as close to being a flying bomb as one can imagine. Five months of my very detailed, personal effort in an engine change, yet I let it go by (chaffing of the aluminum fuel pressure gauge line where it goes through the firewall sandwich clamp). After 20 + hours of safe and very satisfying time back in the air, including two trips to Idaho, it happened. We departed home base for another 3 1/2 hour flight to Idaho with a planned arrival just dark, hopefully ahead of forecast incoming weather. After departure, we smelled gas fumes but couldn't locate the source. I attributed it to a gust that, with full tanks, vented some fuel which drained to the wing roots, thus fumes into the cockpit floor area. We opened all air vents and continued climb out. An hour later, over the Sierras, I kicked left rudder to help with some turbulence and noticed that my heel slid very easily on the metal floor plate. So I reached down and felt the plate. No sand or dirt, but my fingers appeared wet. I reached down again and patted the plate. It was like splashing in a rain puddle - only green! So I felt again. The sole of my left boot was sopping wet, so I felt the rudder bar. Raw gas was running down from above. I instantly knew where it had to be coming from but not really why. We immediately landed at Susanville, removed the seats and looked. Then opened the cowl, removed the putty and pulled the line. Now view this: About 1/4 inch pull moved the crack in the line to the engine side of the firewall. Such movement in flight, or a lack of sealant, would have spewed the raw gas on the end of the muffler, hot exhaust pipe, or down the firewall into hot exhaust gasses! We found a guy on the field who had a piece of line and a flaring tool (I had all other tools) so I had it all replaced in less than an hour.

An interesting thing, with the fresh air vents all open, the spewing fuel was being evaporated fairly well. The next day, we had to land en route for additional fuel to make up for what we lost! We were lucky. Only an unplanned overnight stay, extra fuel, a few bucks and a new "experience".

## **BAGGAGE COMPARTMENT FUEL TANK**

Do you have any knowledge of an STC, Number SA4-271, which is held by Symons Engineering, P.O. Box90002, Airport Station, Los Angeles, California 90009, for a twenty gallon auxiliary fuel tank installed in the Comanche baggage compartment. I wrote to Symons Engineering recently, but my letter was returned by the post office.

**ED:** After doing a bit of research on an STC for this 20 gal. aux. tank, we find that the number of this is SA4-971, not SA4- 271. The address you quote for Symons Engineering is the correct one. I talked with Mr. Symons on the telephone and he indicated that there had been problems in the past with the local post office which he seemed to feel stemmed from the similarity of his box number and the zip code. His telephone number, by the way, is (213) 534-216 1. My suggestion is that you send your letter back one more time.

## **AILERON AERO-TRIM SYSTEM**

A flyer article asked if anyone with a Aero-Trim electric aileron trim system has ever encountered a "runaway" trim situation. Runaway trim is when a trim system suddenly decides it wants to either start operating all by itself or once activated by the pilot, will not stop and runs to an extreme position.

A runaway electric ELEVATOR (not aileron), trim can be a hazardous problem because elevator response is sudden and with great authority. A full up or down ELEVATOR trim can cause some mighty straining at the yoke. AILERON trim is completely different. AILERON trim is very benign, making the response gentle and subtle. You need that action in order to fine tune the plane

around your roll axis. Trimming your plane around your axis is the only way you can get maximum performance, so you want it precise.

It took great engineering design efforts to fool proof the Aero Trim to prevent runaway trim. Stray voltages to the servo motor are an impossibility. The pilot must first push the switch to send current to the servo motor. The switch, being spring loaded, pops back to OFF when finger pressure is released.

After reading the article, I called the member to ask if he had a problem. He explained he wrote the letter before the trim was installed and being the cautious person he is, was, simply curious. The member manufactures transformers, is technically competent and therefore an extremely careful buyer. I admire that.

Among the thousands of Aero-Trims world wide, we had one runaway trim. It occurred in a Lake Amphibian after it had shipped salt water inside the cockpit. Aero-Trim is standard equipment for Lake; one comes on every airplane and they prefer to install the indicator in the floor between the seats. It's handy for the pilot, but also vulnerable for splashing water and splashing in water is what the Lake is all about.

Subsequent inspection proved the owner forgot to flush the plane with fresh water. Time passed and the switch corroded inside. When he next pressed it, it stuck. Now as a safeguard, every switch sent to Lake is packed with grease. No problems since.

The member's Aero-Trim was factory installed as he had to pass through Ft. Lauderdale enroute to business appointments. His twin is beautifully equipped right down to Loran, but he had no room in the panel for the 2 1/4" indicator. No problem, they also fit nicely in the ashtray space.

## **CONTROL WHEEL MODIFICATION**

We have received several calls and letters recently at ICS headquarters in regard to putting rams horn control wheels on Comanches. The parts to order are a yoke (this is the control wheel) and the part number is 32436-02. The old medallion will not fit the new wheel so you will need to order a different one ... Part Number 48657-00.

These parts should be ordered from your Piper dealer. The new wheels are drilled to hold switches for mikes, autopilot disconnect, etc. If you want to cover the holes, you can order the part to do so but it is expensive. . . or you could have your mechanic cut a small piece of metal to fit and put a couple of sheet metal screws through it. After painting black, it can be snapped into place in the hole.

The tapered pin that holds the control wheel on is hard to get out as it has only one opening. . . at the bottom. But, if you take off the old medallion and use a good pair of dikes, you can grasp the pin through the opening in the end of the tube that holds the wheel and by prying up on the dikes, the pin should slide out the bottom.

The switches to fit the new wheels can be ordered. Order PA- 39 switches. ED: RAMS horn control wheels from some newer pipers will fit the Comanche 1.625 inch control column (i.e.; Aztec, Cheyenne, Navajo, Seneca).



## **NOSE WHEEL TIRE MODIFICATION**

This is just a note to add to the nose-wheel tire story. I installed a 15 x 600 x 6PR nose-wheel tire on my 1969 Twin Comanche. Being 2" less in diameter, it does all the good things that the ICS members have written about. On take-off, the aircraft has to be rotated to fly - no more wheel-barrowing. On landing, it is much easier to land with full flaps and not land nose-wheel first. (I used to pull flaps up before touchdown.)

The recap tire cost \$38.00. The tube \$17.80 both fit on the regular rim. It was an inexpensive mod. that improved greatly the biggest weakness of the Comanches. However, when my annual came up, I was denied a 337 approval by the JAX GADO. They wanted an STC. Explaining that 337's were already approved, even for a 500x5 nose-wheel, would not deter them from their position.

I decided to apply for an STC that anyone could buy who wanted to use it. After about 2 months, 25 phone calls, visits from inspectors with tape measures and test pilots, I finally got the STC for the PA-24, 30 and 39.

Those of you who have not been able to get approval and would like to, I will sell it for \$14.95 (ICS members). If you are fortunate enough to live in a district with a reasonable GADO, I envy you. If not, the STC is available and the mod. makes a great airplane even better.

## **TWIN BAGGAGE DOOR MODIFICATION**

Here in Oklahoma we have a lot of windy days when the open baggage door on my Twin Comanche would "sail or fly" up, releasing the baggage door support and down she would slam just as I arrived with both hands full of baggage!

Also, back when I was relocating the battery box to its new location aft of the baggage compartment bulkhead, I was in and out of the baggage compartment door quite a lot and I seemed to be constantly bumping the support mechanism which held the door open. This would cause the door to fall down on me, interrupting the work at the least appropriate time.

My mechanic came up with a great suggestion: "Let's put the baggage door retainer from a Cherokee Six on there!" This is really a slick modification, folks. Just a lightweight strap of nylon webbing with a snap on one end and a grommet on the other. Two small posts are installed on the Comanche, one on the aft side of the baggage door in a Rivnut, and one on the fuselage in the joint made where the fuselage skins overlap and are riveted together. Just take a look at the arrangement on a Cherokee Six. Nothing to it!

## **SWITCH PANEL MODIFICATION**

I recently wrote a letter explaining how I redesigned my instrument panel. The redesign was a lot of work and took a lot longer than I would have ever expected. But it was worth it. In addition to being beautiful, it made the Comanche easier to fly IFR. Plus, there was the satisfaction of having designed it myself.

But there was still a fly in the ointment. Having gotten used to the switch panel layout in Archers, Saratogas and Lances, I found the switch panel layout in my new 1960 250 to be horrible. Not only were there multiple switches for things like landing lights (do any of you habitually land with only one light?), there were switches that didn't do anything. In addition, a previous owner had installed both top and bottom strobes and each had its own switch. To make it worse, the

switches were on opposite sides of the panel! Having landed several times with the pitot heat rather than the fuel pump, and having turned on only one landing light and God knows what else, I decided that I had to do something to remedy the situation.

I had four goals.

1. To remove redundant switches;
2. To combine logical pairs of switches into single switches (e.g., landing lights) thus cutting down on the work load and potential mistakes;
3. To locate common switches together (e.g., lighting) and;
4. To place the pitot heat and fuel pump switches where there would be no mistake in finding them.

The accompanying drawings show that I almost accomplished my goals. The first drawing is the original switch panel layout. The second drawing is the current layout. It turns out that there were only four tasks listed as follows:

1. Move fuel pump switch to the left of the pitot heat;
2. Combine landing lights into the left landing light switch-
3. Combine strobes into one switch and move to right landing light switch location;
4. Remove other strobe, landing light, and T&B switches. The redesign and consolidation left four empty switch holes (one already existed), thus removing the cluttered feeling of the panel and leaving room for additional functions.

Both the landing lights and strobes are wired in parallel so the loss of one won't affect the other. There is a risk that, if the switch or power lead fails, I would lose both devices. I don't consider that a problem. Both are no go items for me and the landing lights aren't required to land. The three lighting switches (Nav/Inst, Landing, and Strobe) are now located together for easy access and there are blanks on either side of them so that they can be operated without looking.

I wasn't able to move the Fuel Pump to the opposite side of the Mag switch because the power lead was too short. The right side of the Mag would be a good location because it would be easily accessible to my right hand in an emergency.

Before we started, we checked the power consumption for the landing lights and strobes to ensure that the power rating on the switches were adequate for the combined draw. Both switches were more than adequate. The whole job took around an hour and a half. We used electrical tape to cover the ends of the leads that were no longer needed on the Turn and Bank and taped the leads out of the way. Lastly, we temporarily labeled both switches that were moved with Dymo labels. I intend to cover the switch panel with a cover that has the correct switch names engraved or silk screened onto it. It was all handled with a 337 signed by the avionics shop that did the work on the instrument panel.

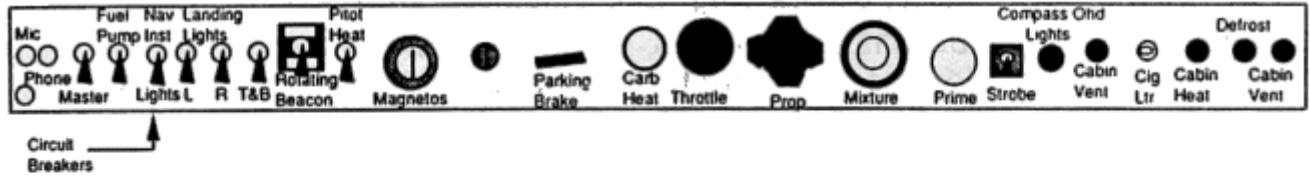

## New Switch Panel

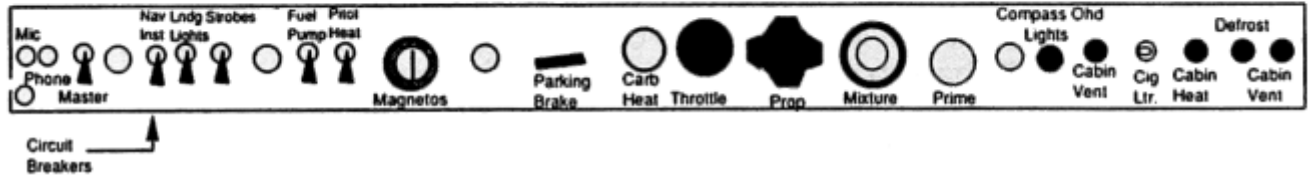

### Original Switch Panel

I still have a couple of changes that I want to make. I am going to move the Overhead/Instrument rheostat on the right switch panel to a location beside the other rheostat on the left instrument panel. When I move it, I plan to change it to the same style of rheostat control as I am using for the instrument lights. I also plan to have an avionics shop change the lead and move the Fuel Pump switch to the empty space between the Magneto/Starter switch and the Parking Brake. At that time, I may install a split Cessna master switch to operate the fuel pumps independently so I can check that both pumps are working (see the May '89 Flyer). I am also going to open up the bottom of the Lexan panel for lighting.

## SPEEDBRAKES

Approach Control says, "turn right to 190 to intercept the final approach course, maintain 3000 until established, cleared for the approach." You are at 4000 feet and the localizer is beginning to center. Well, slow, drop the gear, dive, and hope you can safely reach the glide slope.

As you cross the last of the mountains between you and the airport, you realize that you have a beautiful view of the airport thousands of feet below, but you are too close to safely descend straight in. The only answer is to turn away from the airport and circle to lose altitude.

You are in a straight in descent and you realize that the airport is much closer than you expected and you are going too fast to lower the gear. Now it is either a quick bob upwards to lose speed or perhaps ask permission to do a 360 to lose speed. As you enter the pattern you locate the 152 that the tower told you was downwind. He is only a few hundred feet ahead and you are overtaking him rapidly. So you either exit the pattern or ask permission to do a 360 for spacing.

Ever been in a situation like one of these? Well, there is an answer. A little over a month ago, I had the new Precise Flight Speedbrakes for the Comanche installed on 70P. In the past month and a half, I have put over 90 hours on my Comanche and have come to a startling realization. Like Loran, once you have used speedbrakes, you won't want to fly without them!

What are they and how do they work? In principle, they are very simple. As the picture shows, each unit (one mounted in each wing) consists of two drag plates that extend into the airflow above the wing. In addition, there is an electric motor, a solenoid, a clutch, some microswitches,

some wire, the case to hold it all, and an actuation switch on the instrument panel. To put it into perspective, each unit is 11 1/2" by 5 1/2" by 21, and weighs 6.5 pounds.

What can they do for you? The best way is to find out for yourself. But let me give you some idea. At 65%, my 1960 250 provides a TAS of 145-148 knots. Extend the speedbrake and the nose will drop and you will see 1400 FPM or more at the same speed. You can, of course hold the nose up for less descent rate or hold the nose up for no descent and use them as the name implies, as speedbrakes. Unlike a Mooney 201 installation that I am familiar with, you do have to pitch up and re-trim the Comanche when you extend the brakes to keep from seeing a tremendous rate of descent. I have the feeling that without pitching up, the nose would reach a point that should be described as an "unusual attitude."

If you look back at the examples at the beginning, you'll see some obvious reasons that speedbrakes can be very useful. There are financial reasons as well. No more shock cooling your engine on a fast descent. Hold a little power, extend the brakes, and possibly the gear and down you come, with a warm and happy engine. But there are many other operational reasons other than correcting what looks like gross mistakes or adjustments. For example, I can adjust my position on the glide slope by simply extending the brakes for a few seconds and then retracting them. On a non-precision approach the step down is simple and straight forward. I extend the brakes, hold back pressure until I reach the next step down altitude, and then retract the brakes, and the aircraft is trimmed perfectly and holds the new altitude. No more picking up speed, throttling back, constantly adjusting trim, or any of the other perturbations that make non-precision approaches difficult to fly!

A couple of weeks ago, I landed at Washington National while watching the heavy iron rotate at the intersection of a cross runway. Precise Flight says that the brakes can decrease landing roll up to 30%, so I landed with them out. I don't know how much they helped, but I had PLENTY of space. I think they helped some, but I plan to do some future testing to determine how much.

One thing they do accomplish on landing is to ensure that you are firmly planted. If you fly into ground effect and extend the brakes as you rotate, the aircraft will firmly plant itself on the runway. They may be the perfect thing for short field landings. I would approach experimenting with these kinds of things on landing carefully (possibly with an instructor) until you are very familiar with how they work.

That raises the question of what effect a malfunction would have. There are three possible malfunctions. First, they don't extend at all. No problem, you are flying a normal Comanche again. Get them fixed when you land. Second, what if they don't retract? The main problem will be the excessive drag that they create. Don't go on any long cross countries. But according to Precise Flight, you will be able to take off (albeit on a longer runway), fly, and land with the brakes extended. The main issues are drag and excessive fuel consumption. Obviously you would never take off with them extended, but it is comforting to know that there is enough power to be able to go around. The last possibility is an asymmetrical deployment (e.g., where one extends and the other doesn't). I imagined it as sort of like a Vmc demonstration in a twin. This one sounds spooky enough that we tested it. Other than a slight adjustment of the ailerons (only a few degrees), the aircraft was completely controllable and I am sure that I could have flown to an airport and landed with no problem. Once again, there is the problem of excess fuel consumption, so you wouldn't want to fly far. But the normal remedy is simply to stow the brakes!

Are there any downsides? Well, they aren't cheap. But good things rarely are, and having recently rebuilt my engine, I look upon them as cheap insurance. After all, in the area I fly, you

have to fit in with what Approach Control wants or they will shuffle you off to Buffalo and you might not get to land on the same day you started! That means the occasional/often requirement for precipitous descent rates that a normal Comanche could never do without a tremendous speed buildup and the inherent likelihood of shock cooling damage to the engine.

There was another downside, but I have been assured that it has been resolved. I have a number of mechanical problems. A call to Darryl (Customer Service Manager) at Precise Flight's 800 number gave me answers, if not an immediate solution. Without going into the details, it seems that the brakes I have are operated with a mechanical clutch and the reliability isn't very good. Precise Flight has developed a new version that does away with the clutch and are going to retrofit all current owners at no charge. Having recycled them thousands of times, they guarantee that the new units will work flawlessly.

Now, what about the operation? There is only one additional pre-flight checklist item - you should cycle the brakes. You can install the on/off actuating button on the panel or yoke. Mine is on the panel, but I have flown in a Mooney with the button on the Yoke and I would prefer that. There are only two positions, extended and retracted, and you can operate them up to Vne. So the only other operational issue is to understand that you have to make a pitch correction (at least in my Comanche) when you extend or retract them.

How would I change them to make them better? First, I would prefer not to have to make a pitch correction. You didn't have to on the Mooney. Second, I would like to be able to partially extend them. Maybe 2-3 extended positions, or maybe unlimited range like with electric flaps. I found that you can pull the circuit breaker to stop them part way, but I am sure that is a BAD habit. Those are the only changes I would make (assuming the mechanical problems are fixed with the new version).

The Precise Flight Speedbrakes have given me a great flexibility in operating my Comanche, both in the IFR and VFR environments. I can capture the glide slope no matter how high they turn me on (the limit is my passenger's and my ears ability to take altitude change; I have seen over 2000 fpm descents at reasonable speeds). I can slow quickly to gear extension speeds and then extend gear to descend rapidly through a hole in the overcast or to keep from overtaking another airplane. I can arrive high at an airport (because of miscalculation, terrain, or a desire to take advantage of the fuel efficiencies of operating longer at higher altitudes) and still comfortably reach pattern altitude. And so on, all knowing that I am treating my engine with loving care! All in all, the Precise Flight Speedbrakes have become a mandatory part of my Comanche.

From time to time, I have seen inquiries in the Flyer about installing the O-540 to replace the O-360 (changing the 180 to a 250). In November of 1988, I had that installation made in my aircraft. The installation itself is straight forward - remove prop, engine and motor mount, and nose gear, and install engine, prop and motor mount, along with nose gear. The governor needs to be changed, as does the tach cable. (This is assuming you have the Comanche with the battery box behind the baggage bulkhead and not on the firewall.) It is time consuming replacing the motor mount bolts because of the acrobatics required to reach them, but other than that, it is routine. We used the Piper drawing #21979 and the Piper service manual for references.

So far; so good. Next came the inspection and completion of the Form 337 in accordance with the sample I had obtained from the Society. Guess what? The FAA will not approve this installation because their specification manual 1 AI 5 does not approve this engine for this airplane (page 11, item 109 a and b of 1 AI 5). Yes, I've heard all the arguments, spent hours on the phone, mailed dozens of papers to the FAA, and today my application for a one time STC

languishes with the propulsion division of the FAA. It has been there since last March with no action!

**ED:** This conversion can be done and legally. It is imperative to do the preparation, paper work, and get FAA coordination completed before you commit yourself. This is not a simple Form 337 field approval.

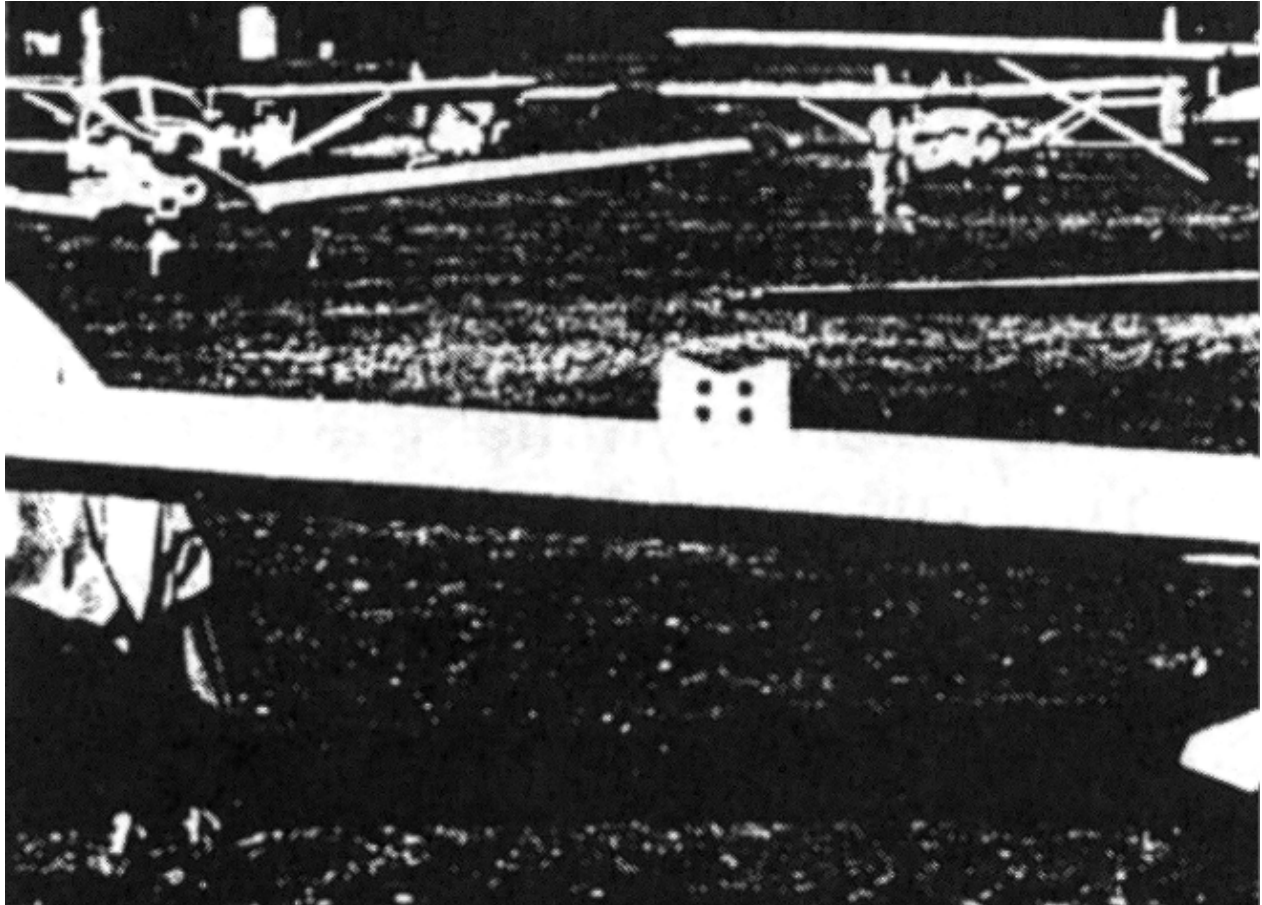

## **FIREWALL FEED THROUGH**

Another modification I made was to the plumbing between the engine and the instruments. It has been mentioned before in the 'Flyer' that the firewall grommets get hard and chafe at the metal lines, resulting in a risk of leakage. The answer is to use bulkhead feed through fittings and I did this by removing the grommet just left of center on the upper part of the firewall, enlarging the hole, and covering it with a 0.025 stainless steel plate drilled for fittings for the fuel pressure, oil pressure, manifold pressure, and gyro vacuum lines. I tried to run the lines parallel as far as possible and I think the result is much tidier than before. Again, this sort of work must be approved to be legal.

## TANKS

In this Flyer I will discuss the operation of the wing tip fuel tank. There are two types of tip tanks used on the Comanche. One is the TT4 which was manufactured and STC'd by Brittain Industries in California, the other is the TT5 which is manufactured and STC'd by Osbourne Tank and Supply in Oro Grande, California.

The TT4 tank was only available for and fitted to the single engine line and is technically the same tank as the later TT5 except for the nose area which had a more rounded and blunted shape.

The TT5 tank was fitted to both the single and twin engine line and was fitted as standard factory equipment on all ex factory turbo charged twins and most C model normally aspirated twins. Both type tip tanks hold 15 U.S. gallons each.

The Brittain and Osbourne tank use the same type thermos cap as the main tanks, but do not suffer from the same water contamination problems. This is because the filler hole is at an angle so it removes the problem of the water collecting in the cup of the cap. At the same time this cap must fit tightly so that it performs in the same manner as the main and auxiliary fuel cell caps.

The pressure vent is located under the wing just below the attaching flange in the form of a 1 /4" pipe protruding from the side of the tank. It should be a prerequisite before flight to check this vent for blockage as the use of the tank with vent blocked up will be noticed by the gradual deformation of the tip tank as the fuel is used from it. (In other words it will suck flat.)

If you should ever run your tip tanks dry they will require "bleeding" prior to using them again. Failure to do this will cause your engine or engines to stop before the fuel lines are cleared of all air.

To bleed the tip tank while stationary on the ground the tank must be over half full, as the fuel pick up pipe is in the center of the tank. To do this, select the appropriate auxiliary tank, select tip tank and open center drain valve. The fuel will drain under gravity to expel all the air in the fuel line. You will have to collect at least 2 litres of fuel from each tank to effectively clear the system. The same will apply to the opposite tank.

Preflight checks on tip tanks is to check the fuel vents as stated and to select each tip tank in turn and listen for the solid "click" of the transfer solenoid, see note.

If you have tip tank caps which do not seal properly the new type cap is available for them also.

### NOTE:

Not all Comanches have this solenoid system. Most singles have the dual selectors. The 180 is the only single capable of using solenoid valves piped through the mains. The reason for this is that the over the valve restriction is too great to give the higher horsepower engines enough fuel at full rich full power conditions. The solenoid valves are piped into the aux. system on all other Comanches because the aux. and tips are only used in cruise configuration and therefore can supply enough fuel in this case.

## THE ULTIMATE SPEED MOD

In February '92, US Aviator carried an interesting article first brought to my attention by Joe Shelton, way back in April. "NEW COWL is worth an extra 22 MPH," the headline claimed, and

seeing they were referring to our Comanche I thought, "We'd better look into this for the Flyer." I'd heard a lot of rumors and listened to some skeptics, so went straight to the source to get the facts.

ICS member Dave Pratt, #2583, of Melbourne, Florida, has been working over five years and invested around \$100,000 to develop his new fiberglass cowling for his 250 Comanche and is about to go into production with the 250 and 260 cowlings. When talking to Dave, he said it not only makes the airplane look a whole lot better, but it gives him an extra 22 MPH in cruise speed and seriously cuts take off roll while improving rate of climb by 200 FPM. The new cowling is designed to basically retrofit the existing airframe structure. There are no cowl flaps, we use augmenters instead. The cowl encompasses a full length set of nose gear doors similar to the twin and the inlet areas are also closed way up, Pratt added, "We've got good engine cooling - very, very even temperatures, the oil temp stays right around 200 degrees, which is right about where it was before we started." He concluded, "There is only about a 5-10 degree cylinder temp variance over all."

"Installation is not too complicated," Dave said. On the 250 the installation includes relocation of the oil cooler, the installation of a dual exhaust system and the placement of the gear door structure. On the 260's, it's just a matter of moving the oil cooler to the firewall. The 260 already has the dual exhaust, so you won't be looking at that expense in the installation,

Pratt added that he has a company developing the exhaust systems for the 250 from stainless steel rather than the traditional carbon steel Piper used. It is anticipated the new exhaust system will be in the \$1500 to \$1800 range rather than the original \$4800 for the Piper equivalent.

The new cowling will be made under license by Ken Rickert of Globe Fiberglass of Lakeland, FL, in accordance to the STC and Bob Meier of the Mod Squad in Venice, FL, will be doing the installations. Almost everything included in the installation is prefabricated and a lot of the parts the Mod Squad will be using are Piper parts. They've kept it as simple as they can. It does include new engine baffling, etc. Over all, the new cowling involves about 40 man hours to install, which is built into the final price.

One of the nice things about the new cowl is that it can be repaired just about anywhere. If the cowl is damaged somehow, you can simply remove the damaged part and send it back to Globe Fiberglass. They'll repair it by running it back through the mold or simply replace it, which is comparatively inexpensive.

"The FAA placed some stringent requirements on the development of the modification," Dave said, "because it is an aerodynamic structural fairing. The flight testing was extensive. We developed seven cowlings in all, three were used in testing and development, the other four in building the molds. We flight tested the cowling for over 250 hours, including placing the airplane in a 240 MPH dive testing for ballooning - that's 17 MPH faster than the FAA wants to see. The Hexel glass, flame retardant cowling is well reinforced and is very strong indeed. It passed the most grueling tests with flying colors."

"One big question that keeps coming up," Dave said, "is did you keep it the same as the old cowl where you can open both sides for good access to the engine? We did just that! Knowing the avid Comanche drivers like to open the cowl and check his engine for oil leaks, etc., we made easy access one of our major considerations in the design stages. One person can remove and replace the cowling in approximately 35 to 40 minutes. For easy access to the air cleaners the nose bowl is separate, you can remove the nose bowl without having to remove the top. Both



the top and the bottom can be removed independently. The gear doors are part of the substructure built into the airframe and are not removed with the cowling."

"We took the new cowling to- Oshkosh last year," Dave said, "and the response among the Comanche drivers was excellent. We've flown the plane to one or two air shows and the interest shown is encouraging. So far we have 33 Comanche owners with expressed interest in the cowling. We'll be taking the proto model to Louisville for the convention and will also have a booth to introduce the cowling to the ICS members."

"On the question of costs, we were advised the 260 would be \$11,999 fully installed, The 250 a little more because of the new exhaust system required. Over all, the new cowling will not only enhance the value of your Comanche, but will greatly increase the performance as well. All the necessary STC's are in hand." Dave, who owns an auto dealership in Titusville, Florida, will market the new cowling through Aviation Performance Products, Inc., a company he developed especially for his "hobby." For further information you may call Dave Pratt at 407-268-8970 days, or Bob Meier of the Mod Squad at 1-800-325-9445, or by writing to Mod Squad, 220 East Airport Ave., Venice, Florida 34285.

We asked Dave for some performance statistics developed in testing the final product and reproduce them below for your perusal - impressive indeed. Incidentally, Dave Pratt was Vice President of ICS in 1985. He was also the Southeast Tribe Chief for four years up to 1984. The Comanche warrior was said to be the fastest and strongest fighter that was, do I see a reflection of that Comanche spirit here?

#### PERFORMANCE COMPARISON

	Comanche 250	Comanche 260	App Inc. cowl
Gross weight (lbs)	2,900	2,900	2,900
Kit weight (lbs)			60
Takeoff over 50' obstacle (ft)	2,050	2,050	1,700
Landing over 50' obstacle (ft)	1,510	1,510	1,510
Top speed, Vne (mph)	203	203	203
Cruise 75% (mph)	173	173	203
Cruise 65% (mph)	164	165	186
Cruise 55% (mph)	158	160	180
Fuel Consumption (gph)	12	12	10.5
Stall ldg config (mph)	63	63	61
Altitude loss (ft)	125	125	85
Stall t/o config (mph)	71	71	67
Altitude loss (ft)	250	250	160

**Note:**

These figures based on use of PA24/250-260 at gross weight of 2,900 lbs. Rate of climb figures are in feet per minute, with landing gear and flaps retracted. Piper figures are those listed in the manufacturer's POH.

## RATE OF CLIMB COMPARISON

Altitude	Piper	App Inc.
sea level	1,375	1,600
2,000	1,210	1,500
4,000	1,100	1,360
6,000	985	1,200
8,000	850	1,100
10,000	750	900
12,000	600	785
14,000	500	600
16,000	375	415
18,000	215	250
20,000	100	195
22,000	0	0

## **AD 79-20-10, ALTERNATE COMPLIANCE.**

### **AD79-20-10**

#### **Aileron Nose Rib Reinforcement Alternate Compliance**

One of our members, Gil Dahl (ICS 744), has come up with a much simpler method of compliance with this AD, and this has been approved by the FAA as of March 4th, 1993.

This uses just the four 20234-42 bulkhead assemblies from kit #763-893. Gil's method removes 128 fewer rivets than the method called for in kit #763-893. Instructions and drawings for this follow.

#### **ICS Report #10193 - Dated March 4, 1993**

#### **ICS Alternate Means of Installing Piper Kit 763-893**

1. Remove ailerons per service manual instructions.
2. Place the ailerons on a padded bench.
3. Remove the balance arm by removing nuts, bolts and washers. [ Note the relative position for reinstallation.]
4. Drill out the 16 rivets shown on the alternate procedure Drawing ICS - 01.
5. Carefully spread the forward skin open 1 5/8" and insert a spreader block (short 2 x 4) into the opening near the bulkhead.
6. Drill out the three AN470-AD 4-5 rivets attaching each counterweight bulkhead to the spar.
7. Remove the bulkheads and inspect for cracks with a 1 OX glass, also inspect the aileron spar for cracks.

8. If any cracks are found in the bulkhead or spar, remove the additional rivets shown on the instructions furnished with Piper kit #763-893. Inspect the aileron reinforcement plate (Piper part #20234-22) for cracks. Replace all bad parts. Refer to Piper Service Letter #850.
9. If no cracks are found in the bulkhead or aileron spar, proceed with this alternate procedure.
10. Enlarge the three holes where the AN470-Ad 4-5 rivets were located to 9/64 in the new bulkhead part #20234-42 and 3/ 16 in the aileron spar and reinforcement plate.
11. Using a 100 degree countersink, countersink the aileron spar to receive an A6-106 countersunk Rivnuts. Install Rivnuts in these holes. Shown on ICS-02.
12. Temporarily install the new bulkheads using #6-32 x 3/4 truss head machine screws MS35206-232.
13. Between the screws just installed, drill two additional equally spaced 9/ 64 holes through the bulkhead and spar.
14. Remove bulkheads and install additional Rivnuts per 10 and 11.
15. Attach new bulkheads to spar using screws, lock washers and Loctite.
16. Remove 2 x 4 spreader bar, allowing skin to return to normal position and replace rivets previously removed.
17. Add two additional AN470AD3-4 rivets through skin and each bulkhead, per kit instructions and ICS-02.
18. Reinstall balance arm as removed.
19. Touch-up rivet heads with matching paint.
20. Reinstall ailerons per service manual instructions.
21. Make logbook entries.

NOTE: Additional parts required not furnished in Piper Kit 763-893:

20 Each A6-106 Countersunk Rivnuts 20 Each #6-32 x 3/4 Truss Head Machine Screws  
MS35206-732 20 Each #6 Lockwashers 1 Bottle Loctite

## **ALTERNATOR CONVERSION TIP**

Hans D. Neubert ICS #7685

Installation of the alternator conversion for the twins, from generators, requires removal of the voltage regulators, paralleling relay and miscellaneous hardware. Installation of the new capacitors, voltage regulators and over voltage relays is not readily accomplished to the existing bulkhead due to the different mounting bolt patterns and the lightening holes.

One alternative method is to fabricate a sheet of .040 aluminum to the same size as the bulkhead, and mount all the new components to the aluminum panel first. Then the aluminum panel is attached to the existing bulkhead using 5 AN3 bolts and 1/2" standoffs, one in each corner and one near the center. The resultant installation is very tidy and looks professional. Consult with your A&P/IA to see if you'll need 337 or Field approval before you start.

## **EXHAUST STACK RECOMMENATION: GULF COAST STACKS**

Steen Munter, ICS #10100

I've owned and enjoyed flying PA30 N7997Y over 1000 hrs. in the last 6 yrs. What a nice airplane! I've "done" the interior, avionics, paint, K2U mods, fuel bladders, I engine overhaul, etc., and it's all been a labor of love (and some \$ once in awhile).

The economy, comfort and speed of the "Twinkie" is legend, and like most pilots, I think it goes faster when it's clean, so I'm always cleaning between annuals and maintenance visits. As the years have passed, I've become increasingly concerned about the slow deterioration of the exhaust area where the hot gases flow directly onto the stainless steel part of the wing. Two years ago, when stripped for painting, the aluminum had large areas of filiform corrosion in the area behind these exhausts on the wings, flaps, and stabilator. So, I have redoubled my efforts to "keep it clean". After only a 3-5hr X-country tho', this area was dirty with exhaust deposits. I got pretty good at cleaning!

Now, my question: Why didn't anyone tell me about Gulf Coast Stacks? Three weeks ago I installed a set and have flown two trips totaling 10 hrs. and it is spotless under my wings! Plus, of course, all that heat is no longer hitting my wing surface and the deterioration will stop completely. I can't believe I spent all those hours of labor (of love) under those beautiful wings when this mod is available.

I heartily recommend these exhaust extensions to all Twinkie drivers. The guy to contact is: Floyd Painter, Gulf Coast Stacks, P.O. Box 817, Foley, Alabama, 36585. Phone 334-943-3653.

Cost was about \$300 and they took me 35 minutes to install, the most difficult part of the installation being disconnecting and reconnecting the cowl flaps. By the way, be a big spender and buy a new 1/4" drill bit to drill the holes. You will understand after you watch someone drill the 4 holes in the heat treated exhaust pipes with a dull bit.

I also recently put my Altimatic II autopilot into operating condition. What a surprise, and what an autopilot! But that's another story.

See ya around the patch, and keep 'em flying (safely).

## **ELECTRONIC IGNITION**

Tom Srachta, ICS #02483

For the last three years I've been following the significant development of the Electronic Ignition System (Lasar) which is produced by Unison Industries. Over the years the people at Unison have been willing to discuss Lasar and even share information and opinions on the equipment as it was developed. I was pleased to read that this system was to be installed in the new Cessna I 72's but apparently the deal fell through. I'm sure you have seen some articles discussing this system and its potential advantages. I will not attempt to reproduce all those thoughts and technical specs, but a very brief description of the system and its operation would be pertinent.

The system consists of two pretty basic Slick mags. These magnetos operate similarly to ordinary magnetos, but they have at least one unique characteristic: they can be deactivated. The primary magneto function can be suspended and an electronic "brain box" will take their place. In fact "normal" operation is with the old primary magnetos inop and the brain box on line. If any fault is discovered, the brain box will default to the old primary ignition system and your airplane will be just as it is now. In reality, you move from two complete ignition systems to three ignition systems. In the system we chose, there are no impulse couplers. This means that if the brain box fails it would probably not be possible to start the engines, (It takes 500 rpm to windmill start.) but once running they would continue to operate. If you do a lot of off road flying I understand that a mag is under development that would have an impulse coupler. This would allow you to get back to civilization with the airplane carrying you, instead of you carrying the airplane.

So, what's the big deal? Actually this is quite a big step forward. With the brain box operational your ignition system has some new tricks to perform. The black box (and it actually is black) has the ability to advance the ignition timing. This is as revolutionary as cold-blooded creatures being replaced by warm blooded critters: an evolutionary step which all of us (with the exception of senior members of Congress and some FAA personnel) have benefited from greatly. Timing can be advanced up to 40 degrees. This advance is most important at cruise settings, especially at high altitude cruise. Test data that I have seen seems to indicate a 4 to 15 percent efficiency improvement. The folks at Unison seem to be down playing these improvements. I think that they are wise in doing so because of basic human psychology. If we are told to expect the maximum possible gain, and we get it, we will still complain that we didn't get a little more besides. However, even a four percent increase is significant.

Let's take a look at this. In our particular aircraft ( PA 30) and engine (IO-320 BIA) let's try to guess at what this could mean. Our 160 hp engine is using only 65% of its power at the altitudes where we prefer to travel. As a rule of thumb higher is usually better for efficiency in our aircraft because you get more speed for less power as you climb. (Remember all those lines that lean to the right in the manual?) At 11,000' we are using 208 ponies (104 hp per side) and 16.2 ghp best power or 15.1 gph at economy cruise (these numbers are our experience, not book numbers, so your mileage may vary.) A four percent efficiency improvement would save almost .7 GPH best power and .6 GPH at economy cruise. Or, you could opt for an improvement in power and add over eight hp (four hp per side) to the old bird. This means more speed because we could now pull almost 67% power at this altitude.

Personally, my experiences with converting a fleet of trucks to electronic ignition from standard systems (remember even those old ignition systems were still light-years ahead of aircraft technology) makes me believe that this might be a low ball number. Just think of what a 10% or 15% improvement would mean. We will keep you informed when we fly the system. See how we leap to the higher numbers!

## The Decision

Should we go with the Lasar system? Let's list the factors that influenced us. First, there is the performance increases that might be gained. Nice, but that is not enough to make us drain our pockets. Second, this is leading edge technology and I am an addict for new and improved (whatever that means). However, my partner is saner than I am. Third, we get to throw out those money-pit Bendix mags. Half the AD's in our Adlog are on the magnetos. (Now, both of us have our noses pressed on the shop window, but we are not yet in the door.) Last, our 500 hour AD is due. More money potentially down the same old hole. Don't stand in our way. Where do we pay?

Actually there may be additional reasons for going Lasar in the future. This brain box learns a lot about your engine. It is constantly sampling rpm, manifold pressure, and CHT. Hence the potential to put that information to use in other ways. It appears that automated mixture control is just down the road, and automated propeller function appears to be in more than just the "maybe" stage. Think about it. This is how the big guys fly. Single lever power control with speed-of-light computer management. Even better, we still would have real honest-to-gosh mechanical controls to override the electrons if the brain goes insane. Heck, I'd be happy with an accurate tach. (Which is hinted at in the literature and I'm told is in the works.)

We called John at Cooper Aviation Supply Company, Inc. (Illinois, 800.654.4944). He encouraged us to talk with Unison in Rockford, Illinois, where the system is made, for any technical advice that we may need. We talked to Harry & Todd in Rockford. We had a raft of questions. The first question was will the PA 30 be part of the STC? After some discussion, he had us added to the list that day. Since no unit had ever been installed in this airframe, and because they were so close (30 minutes) to our home base, Harry agreed to meet us at the airport and help us spec out the system. This personal assistance and attention alleviated our last doubt, which was fear of buying new technology and being stranded. (Anyone who has purchased a computer or software will understand this almost phobic fear. It's induced by such oxymorons as 900 phone numbers labeled customer support.) I believe that the Unison people are very interested in this system going out the door as smoothly as possible. In fact, you are charged a \$250 core charge for each of the controllers. In addition a \$150 core charge is made on each of the mags. These charges are refunded when you turn in your old mags and register the new ones. Soon our order was entered and UPS was bringing packages to our door. I'm sure my UPS man would have a retroactive hernia if he knew how many airplanes he had delivered and carried to my door step. Maybe I'll get him a truss for Christmas, just in case.

#### I Feel Your Pain

What does the system cost? Well, it is not cheap. You can look at the enclosed spread sheet. These are retail prices. No doubt you could get significant discounts, but you didn't hear that from me or read it here. In our figures you will note that there are items included that you may not require. Sales tax, ignition, high voltage harness, spark plugs, dual CHT probes, subscription & manual, and timing box, to name just a few. Is it worth the cost? Like everything else, that depends on how you fly, where you fly, the number of hours you accumulate per year, and your individual situation. There is also the possibility that we have escaped (hopefully) the cost of a number of annoying and repetitive AD's. It would be especially appropriate to step up to the Lasar system if you had to replace or do a major rebuild on your existing magneto system.

#### Additional Info.

Our engines are high time, with channel chrome cylinders (about 1600 hours). So one of the concerns we had was whether this installation could be detrimental to our engines. We were assured that there would be no downside for the engines. We have been using fine wire iridium spark plugs. They have been less prone to lead fouling. After about 1000 hours they are finally starting to show some wear. This new system produces a hotter spark and for a longer duration but with less amperage. Below about 700 rpm the spark is boosted even more. Surely the hotter spark will help cold, hot, and flooded starts. An additional tidbit is that the mags do not reverse polarity like the old Bendix mags. (I can never remember which is positive and which is negative who cares?) This means that there is no advantage to rotating plugs top to bottom for leveling plug erosion. Unison set the polarity to remove metal from the massive side of the plugs (whichever polarity that is). How will all this come out in the wash? We will let you know. We did

purchase a complete set of massive electrode plugs to keep in the aircraft, just in case. This I is because of the aging condition of the existing plugs not due to fears about the new ignition.

The spark advance programming apparently kicks in when the manifold pressure drops below about 27 inches manifold pressure. It then continues to advance with reduced manifold pressure and rpm up to a limit of around 40 degrees BTC. If CHT's get near redline then the black box retards the timing back to the original base timing of 25 degrees. From this information you can correctly deduce that the system should show its biggest advantage at lower power settings. Since the airplane is more efficient at higher altitudes, we are hoping for a noticeable improvement at our favorite altitudes of ten, eleven, and twelve thousand feet. Of course, by governmental red tape decree and justifiable attorney fright, you are prohibited from anticipating any actual improvements when you are alone or in the planning of any flight. This also means that any single engine climb or service ceiling improvements (which would seem to logically exist) also fall into the liability blackhole to wit and hence forth not withstanding in the first par thereto fore and into the alternate legal logic universe.

The brain box does require battery power to operate.

Therefore, no prop starts (Ugh, I'm too old/smart, anyway) with a dead battery. It also requires more electrical power during the starting phase than it requires to maintain itself once it's running. Still, even if your luck runs like mine and the airplane goes totally dark, the ignition system drops back to a condition similar to your current normal operational state. This is very reassuring to us.

## The Installation

The major components consist of: left and right magnetos (unlike the old mags there is a difference between left and right), the controller (brain box), and a low voltage harness that connects them. The Lasar system requires a CHT probe. Because we have a multi-probe CHT we ordered a dual probe to avoid losing any monitoring capability. Not included in the kit are any of the mag gaskets. (Come on Unison; if you buy new mags, how about tossing in the gaskets.) I would also recommend ordering mag pad gaskets and the hardware for tapping into the manifold pressure line. We used the following for tying into the manifold pressure line: AN 825-4(Tee), two AN 910-4 (Co up] Coupling ) two AN8194 (Sleeves), and two AN818-4 (Nuts) for each engine. You could tap the manifold pressure port on a different cylinder, but that could mean more plumbing and there is always a chance that the pipe plug might not willingly come out of your cylinder. This would ruin my day. Void where prohibited, I didn't mean it, not valid in all states, countries or kingdoms, I still don't mean it, under penalty of death or marriage, You can't make me accountable, and subject to any ridiculous rule that some ambulance chaser, legal parasite can think of, at any time for any reason, If you act on this it's your fault.

Most installations will mount the controller on the firewall. However, we elected to mount the controller in the engine nacelle behind the firewall and on the bulkhead which is about 12 inches aft of the firewall. Our reasoning was that the wiring would age better and it would be a neater looking installation. (Unison claims all the hardware and cables will easily stand up to the weather under your cowling, and I have no reason to doubt them.) We decided to go through the firewall where the old "P" leads were located. This would allow us to tap into the manifold pressure lines in the back of the firewall and use the existing, J1A, J2A, BA, and J4A mag wires to save extra wires or splices around the engine or holes through the firewall.

To make this cutout in the firewall, we removed the "P" lead box, condensers, and blind nuts. (You don't need them any more, but they have value, so make a present of them to your FBO.) I

then made a jig to locate the center for drilling two 1.5 inch holes for the cutout. Two plates were fastened from stainless steel to make a cover plate for the new through hole. The nice thing about this installation is that the new coverplates also use the existing mounting holes from the "P" lead box so you have nothing to plug or cover. I will be glad to donate this jig to ICS, but it was easy to make. The coverplate mounting holes are on 2.5 inch and 3.5 inch centers. With some careful use of high temperature silicone, the modification of the firewall was complete.

Installing the brain box, per directions, required the use of four 1/4 inch bolts and AN 970 washers (none of this hardware is included in the kit.) It seems like overkill, but we did it. In the installation video (which you can order for \$35 retail) it appears that in one example Unison was using Rivnuts(This would certainly simplify installation.) We made a jig for aligning and drilling the black box mounting holes. If you can borrow an angle attachment for your drill your life will get noticeably easier. The manifold pressure line was cut and about a one inch length of tube needed to be removed to allow for the "T" fitting. The controller comes with the required hose fitting which features a mandatory restrictor hole. A loop of 1/4 inch tubing completed the plumbing. Now for the wiring. Although the manual allows for the use of butt or knife connectors, in our Twin Comanche we had some unused terminal studs, so we opted to use them to connect the power and "P" leads. It is necessary to pull a dedicated 12V ten amp power line into the nacelle. For me, pulling wire ranks right up with dental surgery as a recreational past time. To keep the fun to a minimum, we decided to pull some extra wires in anticipation of electronic tachs or other possible future goodies. The circuit breakers were installed on a subpanel under the appropriate mag switches, to make a logical installation. (Don't tell anyone, but if you pull the breakers the aircraft cannot be started... sort of like an anti-theft cutout.)

Installing the mags and timing them was straightforward and well documented.. Since we were the first on our block to have the new system, we had to invest in the timing box that is unique to the Lasar system (6 AAA batteries NOT included). New ignition harnesses were also installed. It turned out to be impossible to get ignition leads that were the same length as our non-Slick harnesses. The new ones were at least six inches longer than necessary on most leads. This harness is way too long. We routed and rerouted, but we still have loops. After we debug and thoroughly familiarize ourselves with the operation of the system, we plan to shorten the leads. We tried to get Unison to exchange for a better fitting harness, but they wouldn't do it. They attribute the problem to Uncle Sam... "these are the approved part numbers for the installation, no substitutions."

The installation has gone smoothly. As always, it seems that we run into some maintenance items that always take more time than our primary project to get ironed out. We would estimate that if you were just installing the Lasar system and you hung it on the firewall you could probably be done in a long day. It is probably a two person job. So, make a friend and do both of your airplanes together. It took us more than one weekend for our behind-the-firewall I installation. If you have a maintenance shop that has done a few of these installations, I'm sure that practice makes quicker.

### First Contact

For safety's sake, it takes a full turn to activate the ignition system for starting. Our airplane has always been an easy starter. We have copper cables and on one side a B&C mini starter. Still, the engines start at least as quickly as before. However, they seem to run more confidently during the first few seconds, after start. Our engines have always been poor idlers. In fact, occasionally the left engine would quit after landing if you pulled the throttles all the way aft. Both engines would balk and idle ugly below 900 rpm regardless of temperature or conditions (Yes, the injectors are clean.) Now they idle as smooth as silk. They really purrrrr. And they idle



smoothly and reliably all the way off the tach's lowest reading. This will surely save us some brake wear. The engines sound different, but I can't describe the difference.

During throttle advance, the engines seem to respond with greater enthusiasm and far more smoothly. There is none of the hesitation that normally accompanies early throttle advances. At 1500 rpm a prop feather check seems exactly as it was before the installation. At 2000 rpm where we would normally perform a mag check, we pulled the breakers to deactivate the brain box. (Switching to a single mag would also temporarily deactivate the brain box.) The left engine lost 100 rpm and the right engine lost 50 rpm. Advancing the throttles back to 2000 rpm a mag check was run. The drops were smooth but slightly higher on the left engine. With the circuit breakers reset and the mags on 'both' the system turns back on after about twenty seconds. How about hot starts? We have never had great difficulty making a hot start. The technique that seems to work the best for us is to slightly flood the engine by running the aux pumps for a brief bounce of the flow gauge. We then use the flooded start procedure and the engines start every time. The difference now is that the engines are very quick to respond and can easily run through 2000 rpm during the time that they would be just 'clearing' themselves before. I can just hear the SSP remarks (Stupid Student Pilot) and assorted anatomical and ancestral improbabilities aimed my way against my overly abundant prop wash.

So far I see no downside for the Lasar system from an operational standpoint. We do have the larger drop than spec on the left engine but Unison has promised to come out and trouble shoot it for us. There is a computer port on the brain box which allows you to plug in any laptop computer for system diagnosis.

## **SLICK LASAR MAGNETOS**

Gordon L. Graham, ICS #0221

Last spring we completed a Millennium Cylinder MOH on a 180 HP Tiger, (from Maryland ), and installed an EDM analyzer, with fuel flow. I participated in the break-in flights. The EDM made the observations of the engine during those initial hours really great. We were having a problem with the oil temperature being higher than my Mechanic desired, so we put about 10 hours on the engine, chasing down the problem. This allowed me to get some stable numbers from the EDM. The Tiger owner had a "full house" and then some, in this airplane. He had also opted for the new Slick LASAR Magnetos, which finally came in about two weeks after we started flying the bird. By then, the faulty sensor on the oil temp had been replaced and all the EDM readings were coming up the same. After the LASARs were installed, we flew the bird again to confirm operation prior to delivery. The fuel flow was a bit over 1 GPH lower than before, for a 15% plus or minus improvement, with the same EGTs and CHTS!

The LASAR could save me over \$500 a year in fuel costs. Almost enough to pay my insurance premium. We were flying the airplane at 75% for the break-in, but to satisfy my curiosity, we tried operating it at 65%, which showed it still saved a bit over the one gallon. This was about a 20% fuel saving, which would bring my range up to over 10 hours at 65% vs the usual 8+ hours.

Frankly I was amazed. We seemed to get better than the figures Slick is putting out. Shows how much difference a more modern ignition system can make. It is still not as up to date as an automotive system, because it still has to have the reliability of the basic magnetos. All failure modes simply revert to the standard magneto ignition. Like Mike, I have had bad feelings about Slicks. According to a couple mechanics, I may have been mistaken though. Their story is that the questionable Slick Mags were supposed to be a cheaper way to go. They were supposed to

go so long, then be replaced. However, most were continued in service through various tricks until they failed. The LASARs are NOT throwaways.

I had looked into them about 4 years ago, when they started to promote them at Sun N Fun. They promised to have them for the 0540 in a year. Two years later I had to go through my MOH and took the opportunity to rebuild my Bendix Mags, including sending the rotors to Sky Ranch for restoring the magnetism to full bore. (A highly suggested idea. The spark is about 50% longer and stronger. ) So of course, now, LASARs are finally approved for my engine. I have too much in the Bendix, even for the great exchange deals being offered. (Which will end just before I give in and buy.) The LASARs are available for the cost of overhauling the Bendix Mags, or less.

There is nothing wrong with the Bendix Mags. Like everything else designed and built in 1900, they were meant to last forever, by just changing parts as they wear. I just did that, which for all practical purposes, makes them new. However, had Slick lived up to their promise years ago, I would have the LASARS instead. There is no safe or approved way I can improve the efficiency of these standard magnetos. They are forever stuck in the "full power" position.

## **FLYING THE LASAR SYSTEM**

Tom Srachta ICS #02483

Preamble: In the previous article (Oct. 97) we discussed the decision to buy Unison's Lasar Ignition system. (Quiz question: What does LASAR stand for?) I received many interesting phone calls and met some very nice people who called and asked questions regarding this system. I was very impressed with the knowledge base and thoroughness of these people. Comanche flyers in general are more than a couple of cuts above other pilots that I talk with.

My motivation in telling you about this new product is merely to get information out to you Comanche owners on what new products are out there and how they work. We are not salesmen for Unison. We are not aircraft mechanics or fixed base operators. We did not receive any special consideration for the installation of this product. Perhaps Unison took some extra interest in us because we were the first PA 30 and first production twin to install this new product. We may have contributed to the PA 30 being among the first batch of STC'd aircraft to receive approval, but that is only because we took an interest in the development of this technology for aviation coupled with Unison's desire to please their customers. It is our sincere wish that our remarks help you learn from our experiences. A secondary goal is that this information be distributed quickly and that this dissemination of information be entertaining. Please enjoy the article and form your own opinions based on your unique situation.

Most Often Asked Would I recommend the system?

Yes. If this system cost the same amount of money as a conventional magneto system, as far as we are concerned you should seek medical attention if you don't install the system immediately. But, unless you have Hillary Clinton's commodity broker as a financial advisor the cost is very much an issue. Only you can decide when and if the cost is justified.

My aircraft is turbo'd, what will I gain?

You need to talk to the Unison people. They can answer this question properly. My guess would be that you would have some of the benefits. For example some benefits may be: longer spark duration, hotter spark (especially at startup), and (at least so far) you get relief from all those Bendix AD's. Perhaps this system is less prone to altitude breakdown, but only the technical

people at Lasar could help you answer this issue. You may not get much benefit from the spark advance feature because it is my understanding that the system only advances the spark at less than 27" manifold old pressure. As I understand it most turbo Comanches push more pressure than this up high and why fly a turbo if you don't use the power that it can give you?

Was it hard to install?

No. And except for the timing box no special tools were required. Although, if this is an excuse to own more tools by all means do so. Remember the person with the most tools at the end, wins.

What did it cost?

The spreadsheet was inadvertently left out of the article. I have included it here. Remember that these are retail prices. We were asked not to publish any discounts that may be available. Also you should note that I've included some items that you might not require (spark plugs, timing box, technical subscription, etc), and I've shown sales tax which may not be an item for you.

I have a PA 39. Can I install this system?

Check with Unison, however at the time we installed our system the PA 39 was not approved because of the counter-rotated engine. This would also mean that any PA 30's that have been counter-rotated would also have to wait until appropriate parts are available. New approvals were already in the works so if you are interested it wouldn't hurt to give them a call.

What have you experienced?

We purposely waited to officially report on the end results of this experiment. We have accumulated over one hundred hours on the Lasar mags. We have had over 50 legs resulting in over 100 starts. However, I would still call our results preliminary.

First, let us discuss the start and idle portion of the flight. Our engines have always been good starters. The only exception would occur early on in our ownership when we would inadvertently flood an engine and therefore fail to use a flooded start procedure, thus prolonging the cranking. Fortunately, we are smarter now and that seldom happens.

The first time you start the engines you will notice a difference. It requires one turn of the prop before the ignition turns on and then the engine is running. Prior to the Lasar system it was necessary to set the throttles at (to me) an uncomfortable high rpm level, around 1200 rpm and then quickly pull them back as the engine started and cleaned up. Now it is possible to crack the throttle and merely crank to start. Our engines did not idle well under 900 rpm. They will now idle smoothly clear off the tach scale. I believe that this is the result of the longer spark duration and the hotter spark that the system generates under 900 rpm. The idle is smooth and reliable although I would refrain from idling below 600 rpm. The spark is always stronger than the standard system, but is boosted even more at idle. This makes hot starts and flooded starts much easier.

What's a hot start? A hot start is when you need to start an engine that is still close to operating temperature. This typically occurs in the summer with high ramp temperatures, for example, during a fuel stop on a long cross-country. This is especially a problem if, like me, you prefer the Indy 506 fuel stop technique. Since my strategy for a fuel stop is to complete the entire procedure in less than 12 minutes, down to up. The bulk of this time should be spent pumping fuel; hence the term "fuel" stop. Unfortunately sometimes the cargo (unruly passengers like wife

and daughters) want to waste time stretching, eating, writing a book or draining their personal sumps and watching a movie in the ladies room. A process that can waste minutes, which is time, which is money ... (cough)... but... I digress...

Our procedure for a hot start is to flood the engine with the fuel pump. This purges the vaporized fuel from the lines and cools them with fresh relatively cool fuel. Then we do the flooded start procedure. Full open throttle and idle cutoff on the mixtures, crank until it lights and then quickly retard the throttle while you slowly advance the mixture. If the aviation gods deem to smile on you the engine starts and runs smoothly. If they fail to start you can follow a common hot start procedure that involves cranking until the battery is dead and then finding an APU or a new battery. During this time the engines and starters have cooled from glowing hot to merely warm and the fuel that filled the cylinders has mostly evaporated thus making a normal start a realistic possibility if not reality. I believe that the spark in this new system is probably strong enough to fire drowned spark plugs with generous coatings of lead, oil, cheese whiz and with only a dim memory of a proper spark gap. So, maybe the fall back procedure can go the way of politician's promises and birds with teeth.

All this is nice but, what about in the air at cruise where we spend all of our time?

It appears to us that at our normal cruise altitudes of nine to eleven thousand feet fuel bums have dropped from 5 to 12 per cent. This is using full throttle operation and leaning to peak or roughness whichever comes first. We can give you actual fuel bums (and I will if you call), but I prefer to use a percentage as your mileage may vary. I don't want anyone using my fuel bum numbers in their airplanes and running short. The engines are very, I repeat, very smooth. If you switch to the backup mode (standard mags) it feels like gremlins are randomly cutting out the spark plugs. It is amazing. It is also now possible to run smoothly even further on the lean side of peak than before, especially over 10,000'. Let's work some numbers. If you bum 15.5 GPH prior to the Lasar mags, then an average savings of 8% would save 1.24 GPH. This would add about 30 minutes to cruising time in a 120 gallon bird.

What else has changed?

CHT's and EGT's have changed. Our CHT's at cruise are running about 25F hotter than before. This is true for both the front and the back cylinders. We do have the Wow cowls which, thankfully, raised the temps on the front cylinders (We could not get 300F during cruise on a front cylinder even on hot summer climbs and winter operation often saw only 200F. We believe that this was too low.) During cruise climbs above 6000' with OAT's well above standard we have seen 450F on number three cylinders. This is higher than before but still well within normal engine specs. Normally at cruise our hottest cylinder (usually #3) CHT's are running around 350F. EGT's run cooler than before by 10F to 40F across the board. The explanation for this is that the hotter, longer duration, more advanced spark cause more fuel to be burned in the power stroke. This means that you are getting more work from the same fuel charge, hence higher temperatures in the heads. This also means that less fuel is burning in the tail pipe, hence lower EGT's. Remember that the system has a temperature probe and if CHT's get too high then the system falls back to standard timing. This wastes fuel by using it as a coolant, putting you right back where you are with standard ignition systems. I don't see a downside.

One unexpected side effect has been higher oil temperatures. Our cowl flaps were pretty much of a takeoff item. Open on the runway, close them with the gear retraction, then forget them until you turned off the runway after landing. Now we do have to monitor the oil temps and on hard climbs during high OAT conditions and occasionally at cruise we do have to open the doors a bit

to avoid excessive oil temps. It is not so much that they run hotter as that the oil temps are quicker to go higher.

Remember that we have the Wow cowl and at cruise that mod does close down the air exiting the engine so perhaps it is a combination of the two mods. We also use 15-50 Shell multi grade oil (if that makes a difference?). We have digital CHT's, EGT's, and oil temps. Believe us, those old Piper gauges are worthless. I have seen our oil temps pushing 240F on the digital gauges and the old analogs are pretty much stuck where they always are.

What aren't we getting?

Well, I haven't noticed any increase in performance as in speed or climb. However, it is a long push on the mixtures to 100 rich of peak where the extra horsepower might be noticeable. Also, we have not had the opportunity to get up to our higher cruise altitudes, like fifteen thousand, where any extra ponies might be more noticeable even leaned. You should note that even with extra leaning the airspeeds have remained at the preelectronic levels. So we are just as fast for less fuel. We haven't reached a conclusion on faster for the same fuel, or faster for more fuel. I just like the same for less too much to try.

I must confess that I am obsessive about clean spark plugs. Even I am impressed with how lead free and healthy the plugs look. We are running a new set of massives instead of our cherished half runout iridiurn fine wires. There is a story behind this so read on.

A few Problems

Prior to flying the airplane, but after the Lasar system installation we were getting very poor operation on a single mag during the ramp check. (During this condition the Controller box is not being used, the system is running like a conventional system on one magneto.) The EGT could not isolate the problem and frankly it seemed like bad high tension harnesses randomly misfiring. But, both sides? On brand new wires? If you recalled we installed pullable circuit breakers (we highly recommend this). Even with the breakers pulled (hence the Lasar system inop) and running on both conventional mags the system was, in our opinion, much rougher than the old Bendix mags. We changed out our beloved fine wire spark plugs to troubleshoot the condition. This did not seem to help. When you ground check the system the specs call for a 50 rpm max drop when the controller (the brain box) is off line and the system is running on both conventionally operating mags. Our right engine was within limits, but the left engine was experiencing a drop of from 50 to 100 rpms depending on conditions. This was obviously out of spec.

With the controller off line and the rpms brought back to 2000 rpm a standard mag check is run with its maximum allowable drop of 150 rpm. Again the right engine was dropping about 100 rpm but the left was falling 170 to 200 and worse yet they were rough.

We timed and retimed and did it all over again. The timing variation coming down to apparent slop in the drive chains and still the problem persisted. However, you should remember that with the electronic system on line the engines literally purred throughout this time period.

Solving the Problems

The Unison people were always willing to take my calls, but eventually we were all stumped. Two techs from Unison volunteered to come out one Friday and check things out. Remember that we are fortunate to live close to Rockford, Illinois where these things are manufactured. As

accommodating as these guys want to be, I doubt that they would trek anywhere anytime. It was a very educational experience. First, a complete inspection of the system and the installation was conducted. No problems were detected. There is a RS232 communication port on the controller so a cable was attached and run into the cabin where it was connected to their laptop. Any laptop will do, although the cable is not wired standard, so you would need to purchase or wire up one yourself. Was this neat! Right there, real time, on the computer was RPM, manifold pressure CHT, and a host of other engine parameters as well as a fault log. Their computer also contained a special program, which gave them access to items like the advance rates.

Understandably this information would be locked out for anyone else. Unison has spent considerable money on dynamometers to develop the optimum advance curve for each engine and I'm sure that they don't want anyone copying or altering this. The information that is available on your engines, real time, is remarkable. Why can't we have instrumentation like this in our cockpits? The long and the short was that everything checked out.

Back under the hood, one of the techs found a hardened and loose induction hose. That did it. I'm removing him from my last will and testament. (I'm really embarrassed) OK, I knew they were old and way past their prime, but so am I, and I don't need to be replaced (no comments please). Besides the engines will be due for major in a year or so and we thought that we would save a few bucks and wait. Well, we raided the piggy bank one more time and replaced the hoses on both sides. Would this make a good birthday gift for that special someone? As expected no change.

However, some changes were taking place. First, the roughness slowly disappeared. Second, the excessive drop on the left engine appeared to be temperature sensitive. We elected to fly the airplane and keep digging out the cause. Here are our conclusions: I believe that the roughness occurred because of some irregularity or contamination of the breaker points probably as part of the manufacturing process. In addition the engines run so well on the electronics that the old ignition, in comparison, is rough. The extra drop on the left engine was due to the fact the idle mixture setting was richer on that engine. If you leaned the bothersome engine the mag drops became acceptable and equal to the right engine. So a few adjustments of the idle wheel and presto, everything is as it should be. At this time I would call our conclusions preliminary and incomplete with regard to fuel burns. We do not have a fuel totalizer so we must run known times at known power settings and then fill the tanks to known fuel levels. Since the airplane is characteristically miserly on fuel, it takes time to build an experienced database. Longer legs are necessary to use enough fuel to give meaningful results and reduce errors due to discrepancies in fueling and refueling. Will we get more power if we run richer at altitude? We don't know yet because we are still exploring the economy side of the curve. Perhaps someone with a totalizer will install these things and let all of us know. We will keep you informed as our experience builds.

In short the system works and the manufacturer stands by his product. If you have any questions please call or write. We love them (we don't hug em or anything) and so will you.

\*Quiz answer: The name "LASAR" stands for Limited Authority Spark Advance Regulator.

## **THE MYTHS OF SPEED MODS; DUAL EXHAUST SYSTEMS, AND COWLINGS**

David P. Pratt, ICS #02583

In 1987 when I began the research and development of the cowling retro fit for the Piper Comanche I tried to keep the modification as simple and as inexpensive as possible. I wanted to install a new cowling with the existing single exhaust, add full length gear doors and control the engine cooling exhaust air with cowl flaps. This approach was soon to be rejected as I did further research and reviewed the project with other aeronautical engineers.

The first myth that I decided to rule out is that you need cowl flaps to control engine cooling exhaust air. A very good friend who is an engineer with Teledyne Continental and designed the engine and cowling installation for the Piper Malibu emphasized that cowl flaps were old technology. Instead of cowl flaps, I incorporated into the cowling an augmented/ramped lower cowling to smoothly flow the engine cooling exit air, exhaust system heated air and tailpipe exhaust. This is basically what the Piper Malibu cowling design incorporated and it worked very well to control engine temperatures and exit air flow. The Beech Mentor T-34 uses augmentor tubes and has been around for 35 years.

The drawbacks are of the old cowling designs is that not a whole lot of engineering went into the designs. Fuel was cheap and all you needed was a cowling to direct air to cool the engine in flight and cowl flaps to allow more air through the cowl to help cool the engine on the ground.

Newer cowling designs incorporate more efficient methods of air management and flow control to cooling and exit air. Inlet air intake size is crucial to getting the correct amount of cooling air into the cowling to sufficiently cool the engine at any angle of attack or flight condition. The dimensions for the heated cooling air exit are equally as important so as not to inhibit the cooling air exiting the cowling causing a pressure buildup to occur in the cowling, which in effect can slow down the air flow and increase engine temperatures and cooling air drag. Ideally, the correct formula is to have a higher air pressure on the cooling inlet side of the engine and a lower pressure on heated cooling exit air side of the engine. Also by ramping or augmenting the flow of the exit air out of the cowling reduces cooling drag and efficiently extracts the air out of the cowling smoothly. Another component to add to this is what you do with the exhaust system and the high amount of heat associated with exhaust.

This was the other part of the theory in our design that made me decide to get rid of the single exhaust system and opt for the dual exhaust system. I was able to incorporate each one of the exhaust pipes and mufflers into the exit air ramps on the lower cowling. I designed our lower cowling with two augmented exit ramps that are of a specific angle to the lower cowling, one on either side of the nose gear doors to exit the cooling air and exhaust system.

Basic meteorological theory shows that when moving hot air meets moving cool air a lot of turbulence is created. If you just dump hot and cold air at each other you create even more turbulence, hence you have another form of cooling drag.

In the design of the cowling for the Comanche I measured intake air pressure and exit air pressure below the engine and at the exit ramp at the lower cowling. With the augmented ramps on the lower cowling I was able to fine tune the exit air pressure for each aircraft after the cowling installation, as I found out that two identical airplanes are not always alike. By installing the dual exhaust system and aiming each exhaust pipe down the exit ramp I am also using the engine cooling heated exit air to further cool the exhaust system air before exiting the aircraft. Also, by ramping the heated exit air through the augmented lower cowling I was able to direct the flow of the air into the slipstream below the aircraft, thereby drastically reducing the cooling air drag.

The problems that you create with the use of cowl flaps is that when they are open they create a lot of drag. When closed, they increase the exit cooling air pressure inside the cowling there by increasing cooling air drag both on the exit side and intake side of cooling air flow. Cowl flaps are a poor compromise for drag reduction. You also have to remember them in your pre-flight check and gump check to open and close them.

Using the augmented ramps in the lower cowling offers very stable air control in all flight conditions. It doesn't exhibit any shock cooling in descents, and in any climb condition, cylinder head temperatures and oil temperatures never see red line. Also, all the intake air inlets into the upper cowling are ramped to ensure a smoother air flow into the engine and reduce/eliminate intake cooling air drag.

Stock cowed Comanches exhibit cylinder head temperatures that vary up to 100 degrees between the front and rear cylinders. With the installation of the new cowling, cylinder head temperatures vary only between 15 and 25 degrees between cylinders on all of the installations so far. The other plus side to the new cowling is that I see an average increase in airspeed and performance of 10-15%.

I chose to use the dual exhaust system from the 260 Comanche. It has been around for a long time and is already approved for the Comanche. A.P.P., Inc., manufactures it out of 331 Stainless Steel instead of the black-iron steel Piper manufactured their system from. The collectors are fitted with slip joints for each cylinder so that they expand and contract with the cylinders helping to eliminate the cracking around the exhaust studs and flanges on the cylinder heads.

A.P.P., Inc., also got approval to install this exhaust system on the 180 Comanche Lycoming O-360 engine. The same mufflers and tailpipes are used as on the 250 Comanche. The collectors are modified for the O360 engine with the same type slip joint to eliminate cylinder head exhaust flange cracking. A crossover or balance tube between left and right exhaust system was considered, but was determined not necessary for this installation. The exhaust system as designed has equal length collector tubes and the performance is much better when neither side is not connected to the other. The balance tube theory is that if one side of the exhaust has more back pressure than the other side, the balance tube allows that pressure to equalize and keep the back pressure constant. Theory is great, but it doesn't always work. All of the high performance exhaust systems have equal length header pipes that are all joined together into one large collector that is ended where the hottest exhaust temperature discoloration stops. This system design gives the best performance and efficiency.

The most efficient way to get the most performance out of any exhaust system is to keep all the exhaust tubes equal length. The tubes then terminate into one collector. The inside tube diameter should be the same as the exhaust port. Mufflers should be the same on each side, and the tailpipes should be as short as possible. The tailpipes should end where the discoloring of the pipe stops due to the exhaust heat. Any pipe longer than this is to no advantage and can only help build up exhaust back pressure. Without the balance tube there is some after-firing from the tailpipe on the 4 cylinder engines under rapid power reduction due to the firing order of these engines. After many hours of flight testing I found no negative performance or engine maintenance problems with this system as installed. The best results come from our customers comments that the airplane is noticeably quieter and that the engine performance is definitely improved.

I get very weary of articles from individuals who claim they made a small clean up modification and get a large speed gain.



There is a factor about speed modifications and aerodynamic clean ups that is never discussed called the Aircraft's Aerodynamic Flight Envelope. Simply put it means that every wing design and fuselage combination, along with the aircraft's gross weight and engine maximum horsepower produces an envelope with a minimum and maximum speed in which the aircraft will perform (sometime called the design speed).

Basically, it means that no matter how much clean up you do, no matter how many speed improvements that you add you can only get so much speed out of a given aircraft design with a given horsepower.

So, if your Comanche does not fly at its maximum safe airspeed in cruise flight, the clean up and speed modifications may help you get a little closer to that speed (which means you have improved the efficiency of the basic design). But you should also know that you may never get to that speed and will probably never exceed it with the given horsepower that is available. Speed modifications or clean up enhancements are not cumulative, so adding more of them does not make your airplane faster; you can only hope to gain a little improvement from each one (if they even work). The more stuff you hang on your aircraft to go faster, the more parasite drag you are also adding to slow you down.

One very basic law of physics is that for every action there is an equal and opposite reaction. In aeronautical terms it means that for everything that you hang on your Comanche to clean it up, you also add a certain amount of parasite drag to slow it down.

So all these claims of Cessna 170's flying at 170 MPH (which only has a 135 MPH VNE) with just a nose bowl clean up, Comanche's getting 40 MPH more with a speed mod or nose bowl addition or a Comanche getting 10 MPH more with the addition of speedspats spitters and splatters is not only nonsense but real Flights of Fantasy. If you want to go faster, you are just going to have to add a bigger hammer (more horsepower) to get there.

There are some reputable companies that manufacture clean up kits, speed modifications and enhancements that improve the design and efficiency of the basic aircraft. You should research each modification and talk to several aircraft owners who have installed them on their aircraft to get information on whether they helped or not.

All of the information discussed above is not anything new, high tech, or unique. All of this information can be found in your public library, the internet or trade publications. Drag reduction information and engineering has been around for years. The home built aircraft community has brought a lot of old technology to new engineering and they build safe, faster and more efficient aircraft than the Manufacturers will ever be compelled to build.

## **AN OLD APPROACH TO MAKE NEW REPLACEMENTS FOR PLASTIC INTERIOR PARTS**

David E. Bice, ICS #11361

I guess Piper either thought the plastic parts they produced for interior moldings in Comanches would last for decades, or that their airplanes would not still be flying at the turn of the century. As Comanche flyers, we know our Comanches are performing just as well now as they did forty or fifty years ago, but sun heated cabins have not been a happy home for the plastic interior parts. My Comanche's black plastic window moldings must have only vaguely resembled their original shapes because they certainly did not fit. Hardened from years of baking in the sun,

many were cracked or broken by retaining screws that were probably over tightened in efforts to make them fit. As we have too often seen, these moldings were somewhere between unsightly and ugly.

So, after investing a lot of time and money to rebuild a 40-year old airplane, I certainly did not want to spoil the appearance of a new interior by using old, unsightly plastic parts. My initial plan was to purchase new plastic moldings. There are good quality plastic replacements available that are probably better than the original parts, and they might even last longer. Globe, for example, manufactures quality interior parts for Comanches. They are relatively expensive, and if I had more money than time, I would have purchased new parts. However, not being rich, and liking to build things, I decided to make new, replacement parts. I'm neither young nor ancient, but still old enough to know that complex shapes can be hand formed out of soft aluminum. The hand formed aluminum wheel pants and fairings on a Monocoupe I once owned were aluminum art. I was fascinated by the beautiful fairings and cowlings on antique aircraft made by aluminum craftsmen of the past, and with a modest amount of experience shaping aluminum, I decided to make new aluminum interior moldings for my Comanche. The goal of this article is to let readers know that aluminum interior moldings can be made to replace the plastic interior parts found in early Comanches, and that they can be made by anyone with reasonable technical skills and a few hand tools. This could also include replacements for some of the plastic overlays that were added to "enhance" the appearance of instrument panels. Remember, these are interior, decorative parts that are not structural, and you do not need to be an A&P to make and install these parts.

There are four window moldings in my 1959 Comanche, two between the windshield and side windows on each side, and two between the front and rear side windows. The moldings have compound curves that require some stretching and shrinking of aluminum, but they are not overly complex. However, to make the compound bends necessary, I had to build four wooden male molds. Unfortunately, the old plastic parts were so warped that they could be used only as a rough estimate of their original shape. So I made measurements from the window frames of approximate sizes (e.g., length and width) and curvature from the top to the bottom of the windows. I used cardboard cut to fit along the side of each window and a magic marker to draw the curve of the window frame. I used clear, knot-free, 2-inch pine for my male molds. I cut the curve on a band saw and used a spoke shave, plane, wood rasps, and sand paper to provide a radius approximately the same as the old plastic part or that simply looked right. It is important that the male mold has a smooth surface because any irregularities will show up in the aluminum part you make. I'm sure some reader who has experience hand forming aluminum might be tempted to go on to the next article at the mention of the word "pine" to make a male mold. However, please remember, I knew I was only going to make one part and not a hundred. If you had any idea of making quite a few, you would have to make the male molds from a good hard wood such as maple. For one part, pine will work fine, and it is much easier to plane and sand to the shape you need. I made one male mold for each part.

The most common alloys used for hand formed aluminum parts is 3003 H-14 and 1100. Either of these would work for this application, but remember that if the stretching you need to do is a lot, you will need the softer 1100. If you don't have any around, you will have to order some from an aluminum supplier. The 1100 is more difficult to find, but Airparts, Inc. in Kansas City (800-800-3229) is an excellent source for the 3003. This vendor is willing to sell small pieces with a minimal cutting charge. Remember, aluminum used for structural components that you might have or be able to find as scrap (e.g., 2024T3) will not work. The temper makes this aluminum far too stiff and it is impossible to stretch and shrink as required for complex bends. Don't even try or you will not only waste your time but you will also be convinced that hand forming aluminum is impossible. Since these are not structural parts, any local source of soft aluminum

will work, and you might try your local heating company or a company that builds trailers as sources of soft aluminum. This is what I did. The thinner the aluminum the easier it will be to form it, and I used 0.020 thick material.

Metal hammers used in body shops can be used, but in the minimal hand forming of aluminum that I have done, I prefer to use a wooden mallet for most of the bending. If you have not purchased a leather making kit for you children (the source of my wooden mallet), you can make one that will work. Purchase a hard wood dowel about 2 inches in diameter. Cut it about 3 1/4 inches long and drill it for a handle made from a 3/4 inch dowel. One end of this double-ended mallet should be perfectly flat with only a small radius at the edge. A sharp edge will leave marks in the aluminum that will be difficult to remove. The other end should be convex with a larger radius at the edge. The surfaces of the mallet should be sanded until they are perfectly smooth because any irregularity in their surfaces will be translated directly to the aluminum you are pounding. Now that you have your mallet, the male mold, and an appropriate piece of aluminum, you are ready to start pounding, or should I say shaping.

Cut out a piece of aluminum that is oversize but as small as possible. Hold it over the mold and try to visualize where the stretching is needed and then start pounding. Forget finesse and just hammer away. After a few minutes you will be convinced that this will never work because the part will only look like beat up aluminum. However, do not give up. The edges have to stretch and the concave surface will shrink. Frequently trimming the excess edges of the part as it gets closer to the shape you want will make forming easier. If the part becomes too twisted or warped, you can discard it and start again. Aluminum is not that expensive. Look at this as a learning process. And if you persist, the piece will have a part that gradually starts taking on the shape you are working toward. The closer it gets to the right shape, the easier it becomes to recognize, the areas to concentrate your pounding. You will (think positively) produce a part that is the one you want. After my parts were close to the desired shape, I did use a body shop hammer and dollies to take out the final dents and irregularities created in the forming process.

The next step is to cut the parts to fit in the cabin. I used masking tape on the windows and upholstery to prevent any scratches that might be caused by checking the fit of the part against the window during the trimming process. Remember to measure twice and cut once, or you will end up with a part that is too small and you will have to make a new one. I had to make a second part after getting too aggressive in trimming, and the pine male mold worked fine for a second part. My plastic interior moldings were held in place by Rivnuts and No. 6 screws. So, it was necessary to drill holes with good precision in the new aluminum parts so they would fit. To locate and mark these holes, I cut the heads off several No. 6 screws, sharpened the cut ends with a file, and screwed the number needed into the Rivnuts in the fuselage with the points out. I then simply held the part up to the window post, pressed it against the sharpened screws, and was provided with clear marks of exactly where the holes had to be drilled. I drilled the holes, and checked to verify that the fit was right.

I had extra headliner material left over and decided to cover my aluminum parts. I used hardware-grade contact cement on the part and headliner material and the adhesive has worked fine for almost two years. Once covered and installed, the parts look as good as anything from the Piper factory. If you would prefer to have a painted surface rather than covered with upholstery material, you can prepare the aluminum parts for painting by sanding the surface to remove any residual forming marks. The aluminum I used was only 0.020, and if you plan to paint your parts, you will have to be sure that you use aluminum thick enough to provide plenty of material so you can sand off any irregularities. Hand formed aluminum will not be perfectly smooth after shaping, but a smooth surface can be produced by sanding. A wet-dry sandpaper of 320 grit is a good place to start. When smooth, go to 400 and even 600 grits to provide a

surface that will accept paint and provide a finished surface without scratches. I admit that I did not know at the start if I would be able to make interior moldings that would be acceptable. And, it certainly took a lot more time than it would have to write out a check for replacement plastic parts. However, this whole process is made worthwhile every time someone notices my interior molding and asks where I purchased them. The reward of a job well done is always satisfying, and in this case enduring and educational. I feel confident that these parts will still be looking good for many years to come. Why didn't Piper simply stamp these out of aluminum in the first place?

If you want additional information and details about shaping aluminum before you start your project, the Experimental Aircraft Association's publications are a good place to look. Restorers of antique aircraft do not want to replace missing aluminum fairings with parts made of fiberglass, and several excellent articles have been published in Sport Aviation that would provide more details about forming aluminum parts. You can purchase these issues of Sport Aviation at a minimal cost from EAA ([www.eaa.org](http://www.eaa.org), or (920) 426-4800). Ones you might want to read include January 1996, pages 63-68, April 1999, pages 46-52, September 1999, pages 78-83, and November 1999, pages 100- 105.

## ON SPEED MODS

Hudson Matlock, ICS #02947

Some recent disappointing experience with so-called speed mods is described below. It is very puzzling in the light of the large number of favorable testimonials from other Comanche owners over past years. Comments of other owners would be appreciated.

My Comanche is N9427P, a 1970 PA-24-260C with factory turbo charging, purchased used in 1980. It was being fitted with a new interior in late 1998 and because it was scheduled to be repainted early in 1999 it seemed to be the proper time to have some of the available speed mods installed.

I obtained information from both Roy Lopresti and Knots 2U and elected to deal with the latter because I thought I should have both flap and aileron gap seals. Aileron gap seals were available only from Knots 2U. The following mods were installed, with the advertised expected speed gains as indicated:

Aileron, flap, and flap-fuselage gap seals	5 - 6 mph
Wing root fairings	1 - 2 mph
Wing fillets	(better landings claimed)
Gear lobe fairings	5 - 7 mph

The installations were done by my local mechanic with some help from me. I believe they were essentially perfect and in accordance with the installation instructions.

It should be emphasized that I am not a fanatic about speed, one of the main considerations was to increase the attractiveness of the plane for sale, probably in a few years (I reached 80 in late 1999). We had a period of perfect flying weather in Texas in November so I took the opportunity to make some very accurate and reliable before and after speed measurements which are tabulated below.

As qualifications of my capabilities, I learned to fly in WWII and have 7,600 total hours. This is my third Comanche, and I have done most of the maintenance during the last 13 years. I have spent all of my professional life as a civil engineer and served as a professor at UT Austin for 30 years of that time, with extensive research and consulting involving experimental measurements. I know how to read an airspeed indicator and a GPS.

All of the measurements were at an indicated altitude of 5,000 feet, maintained very precisely by the Altimatic III autopilot which also was used to keep headings constant. The airspeed indicator is calibrated only in knots and has good resolution. GPS readings were done with an Apollo Precedus. Power settings were at 24-24 which required a touch of turbocharging. Fuel flow was 14.5 gph with the EGT about 100 degrees below peak. The gasoline used for each 30 to 40-minute flight was not replaced so the gross weight decreased slightly during the sequence of flights. My constant weight wife served as data recorder for all of the flights.

Judging from the variations observed during the test flights, I estimate that the probable error of the averages is in the order of one knot or less. Comparisons of results between Sections 1 and 2, (page 20), were clearly very disappointing. I wondered if I had paid more than \$4,000 for snake oil and if there may have been a great deal of wishful thinking in the past. I have not yet seen any significant improvement in rate of climb. Judgment of any benefits of the wing fillets on landings is very subjective and I have not yet formed an opinion.

Since the gear lobes are readily removable, a further test flight was done without them and the results are shown in Section 3 (page 20). It is clear that there was no significant benefit from the gear lobes and they were returned for credit.

Both Maurice Taylor and John Bailey of Knots 2 U thought that the speeds I observed were below par for this model. However, all of the rigging checks and other inspections that Maurice kindly listed for me checked out perfectly. I judge that the performance is about consistent with my two previous Comanches. In any event, I believe that the data tabulated below are valid as comparisons.

So much for speed mods.

**ED:** Tables are missing for this article

## **I HEARD IT ON THE INTERNET ABOUT SPEED MODS**

**Q.** With all the hype on speed mods what is the most effective?

And then the most cost effective?

David Pyle

**A.** Hans Neubert #7685

The following mods are in descending order of effectiveness and speed gain.

1. K2U Aileron and Flap Gap Seals, Wing Root Seals.
2. K2U Gear Lobes
3. Lopresti Flap Track Fairings
4. For Singles, the Fairing aft of the Nose Gear.
5. Johnston Wing Tips (maybe)

Thereafter, you are in the area of diminishing returns. While other mods will still add to your speed gains, their cost/effectiveness ration dwindles.

The new cowl mods being offered are very expensive. Using nomographs Lopresti published in the Flyer in 1992, the payback period (using money saved on fuel) is in the order of 30 years. However, this mod will increase the value of the airplane. Count on 1/2 the cost of the mod being added to the value at selling time.

My rule of thumb,  
\$100 per mile per hour gained - Good Deal.  
\$200/mph gained - still OK, but close to pain threshold.  
\$500/mph gained - forget it.

#### A. Dale Vandever # 2826

Prior to ordering speed mods, there are a number of "non-mod" things that you can and should do:

1. Check the aircraft rigging. With 30 year old airplanes, the rigging is likely to need redoing. Someone will have reported a "heavy wing" and the flap on one side will have been lowered just a tad. This will provide more lift on that side and will also provide more drag. The drag on one side will move the ball off of center. The next mechanic will adjust something, or the pilot will just use rudder trim and generate more drag. Over 30 years this process can, and will, rob you of several knots of air speed. Light Plane Maintenance published an excellent two part article on how to properly rig an airplane. If your airplane is not truly in rig, your mods will be doing good to get you back to Mr. Piper's original, and accurate, performance figures.
2. While up on jacks, check the fit and tightness of the gear doors. Look at the cover picture of the 400 Comanche on the January FLYER. I would expect this Comanche is five knots, or more, slow due to the gear hanging out and the doors not being closed. The gear needs to be fully retracted and the tension on the doors needs to be adjusted to the values listed in the maintenance manual.
3. If you have an earlier model Comanche with the brake pucks on the outboard side of the forks, all of this "non aerodynamic" mechanism is hanging out the bottom into the air stream and robbing you of two or three knots. In the later models, Piper put the brakes on the inboard side and retracted them up into the wing and out of the airstream. The Comanche Tips contain several articles on modifying the "bump pad" inside the wheel well to allow you to retract the entire gear a bit further into the wing. The brake pucks can be moved to the inside during an annual inspection or any routine maintenance at little, or no, extra cost.
4. If your typical load is pilot only, or pilot and one passenger, your cg is forward and the stabilator must generate more downward force to trim the airplane. If this is the case, added weight in the baggage compartment will move the cg rearward, reduce the downward force and drag, which will result in a gain in true airspeed. I see some pilots carrying two cases of oil against the rear baggage compartment bulkhead. Some have made up 25 pound bags of lead shot that is easy to add or remove.
5. The prop is moving faster than anything else on the airplane. Actually, just below supersonic at the tips. Any drag here degrades the aircraft performance. The back side of the prop is where the work is being done. Check the back side for dings, gouges, missing paint, rough spots, etc. Any repairs in this area will increase thrust and air speed.

6. Borrow an electronic portable tach (these are accurate to one or two rpm). If your aircraft tack is reading 2400 rpm and the actual is 2315 you are going to be disappointed in your airspeed. If you spend "big bucks" on mods, you will still be going slower than the other guy with the same mods. You will be the guy bragging about his fuel economy.
7. Keep the aircraft clean and waxed. Particularly the wing leading edges and the belly.

Now, check the depth of your wallet and start reducing that drag that came with the new airplane.